

**TYPICAL ELEVATION  
2 TRACK FRAMES**

**SERIES-390 ALUMINUM SLIDING GLASS DOOR**

DESIGN LOAD RATING FOR DOORS TO BE AS PER CHART SHOWN ON SHEET 3 & 3.1.

THIS PRODUCT HAS BEEN DESIGNED AND TESTED TO COMPLY WITH THE REQUIREMENTS OF THE 2017 (6TH EDITION)/2020 (7TH EDITION) FLORIDA BUILDING CODE INCLUDING HIGH VELOCITY HURRICANE ZONE (HVHZ).

1BY OR 2BY WOOD BUCKS & BUCK FASTENERS BY OTHERS, MUST BE DESIGNED AND INSTALLED ADEQUATELY TO TRANSFER APPLIED PRODUCT LOADS TO THE BUILDING STRUCTURE.

ANCHORS SHALL BE CORROSION RESISTANT, SPACED AS SHOWN ON DETAILS AND INSTALLED PER MANUF'S INSTRUCTIONS. SPECIFIED EMBEDMENT TO BASE MATERIAL SHALL BE BEYOND WALL DRESSING OR STUCCO.

A LOAD DURATION INCREASE IS USED IN DESIGN OF ANCHORS INTO WOOD ONLY.

ALL SHIMS TO BE HIGH IMPACT, NON-METALLIC AND NON-COMPRESSIBLE.

MATERIALS INCLUDING BUT NOT LIMITED TO STEEL/METAL SCREWS, THAT COME INTO CONTACT WITH OTHER DISSIMILAR MATERIALS SHALL MEET THE REQUIREMENTS OF THE 2017/2020 FLORIDA BLDG. CODE & ADOPTED STANDARDS.

THIS PRODUCT APPROVAL IS GENERIC AND DOES NOT PROVIDE INFORMATION FOR A SITE SPECIFIC PROJECT, i.e. LIFE SAFETY OF THIS PRODUCT, ADEQUACY OF STRUCTURE RECEIVING THIS PRODUCT AND SEALING AROUND OPENING FOR WATER INFILTRATION RESISTANCE ETC. CONDITIONS NOT SHOWN IN THIS DRAWING ARE TO BE ANALYZED SEPARATELY, AND TO BE REVIEWED BY BUILDING OFFICIAL.

DESIGN LOADS SHOWN ARE BASED ON 'ALLOWABLE STRESS DESIGN (ASD)'.

MANUFACTURER'S LABEL SHALL BE LOCATED ON A READILY VISIBLE LOCATION IN ACCORDANCE WITH SECTION 1709.9.3 OF FLORIDA BUILDING CODE. LABELING TO COMPLY WITH SECTION 1709.9.2.

THESE DOORS ARE RATED FOR LARGE & SMALL MISSILE IMPACT. SHUTTERS ARE NOT REQUIRED.

- A- CONTRACTOR TO BE RESPONSIBLE FOR THE SELECTION, PURCHASE AND INSTALLATION OF THIS PRODUCT BASED ON THIS PRODUCT EVALUATION PROVIDED HE/SHE DOES NOT DEVIATE FROM THE CONDITIONS DETAILED ON THIS DOCUMENT.
- B- THIS PRODUCT EVALUATION DOCUMENT WILL BE CONSIDERED INVALID IF ALTERED BY ANY MEANS.
- C- SITE SPECIFIC PROJECTS SHALL BE PREPARED BY A FLORIDA REGISTERED ENGINEER OR ARCHITECT WHICH WILL BECOME THE ENGINEER OF RECORD (E.O.R.) FOR THE PROJECT AND WHO WILL BE RESPONSIBLE FOR THE PROPER USE OF THE P.E.D. ENGINEER OF RECORD, ACTING AS A DELEGATED ENGINEER TO THE P.E.D. ENGINEER SHALL SUBMIT TO THIS LATTER THE SITE SPECIFIC DRAWINGS FOR REVIEW.
- D- THIS P.E.D. SHALL BEAR THE DATE AND ORIGINAL SEAL AND SIGNATURE OF THE PROFESSIONAL ENGINEER OF RECORD THAT PREPARED IT.



**af c**  
**AL-FAROOQ CORPORATION**  
 ENGINEERS & PRODUCT DEVELOPMENT  
 9360 SUNSET DRIVE, SUITE 220 (C.A.N. 3538)  
 MIAMI, FLORIDA 33173 TEL. (305) 264-8100 FAX. (305) 262-6978  
 COMP-ANL\W12-31TMM

SERIES-390 ALUM. SLIDING GLASS DOOR (L.M.I.)  
**Assura Windows & Doors, LLC.**  
 1543 N. Powerline Road  
 Pompano Beach, Fl. 33069  
 Tel. (305) 887-2646 Fax. (-)

no	date	description
A	08.06.12	GENERAL REVISION
B	02.20.15	GLASS TYPES G6 & G6A ADDED
C	01.10.18	UPDATED TO 2017 FBC
D	09.23.20	UPDATED TO 2020 FBC

revisions:

date: 06-15-12  
 scale: 3/8"=1'-0"  
 dr. by: TARIQ  
 chk. by:

drawing no.  
**W12-31**

sheet 1 of 13

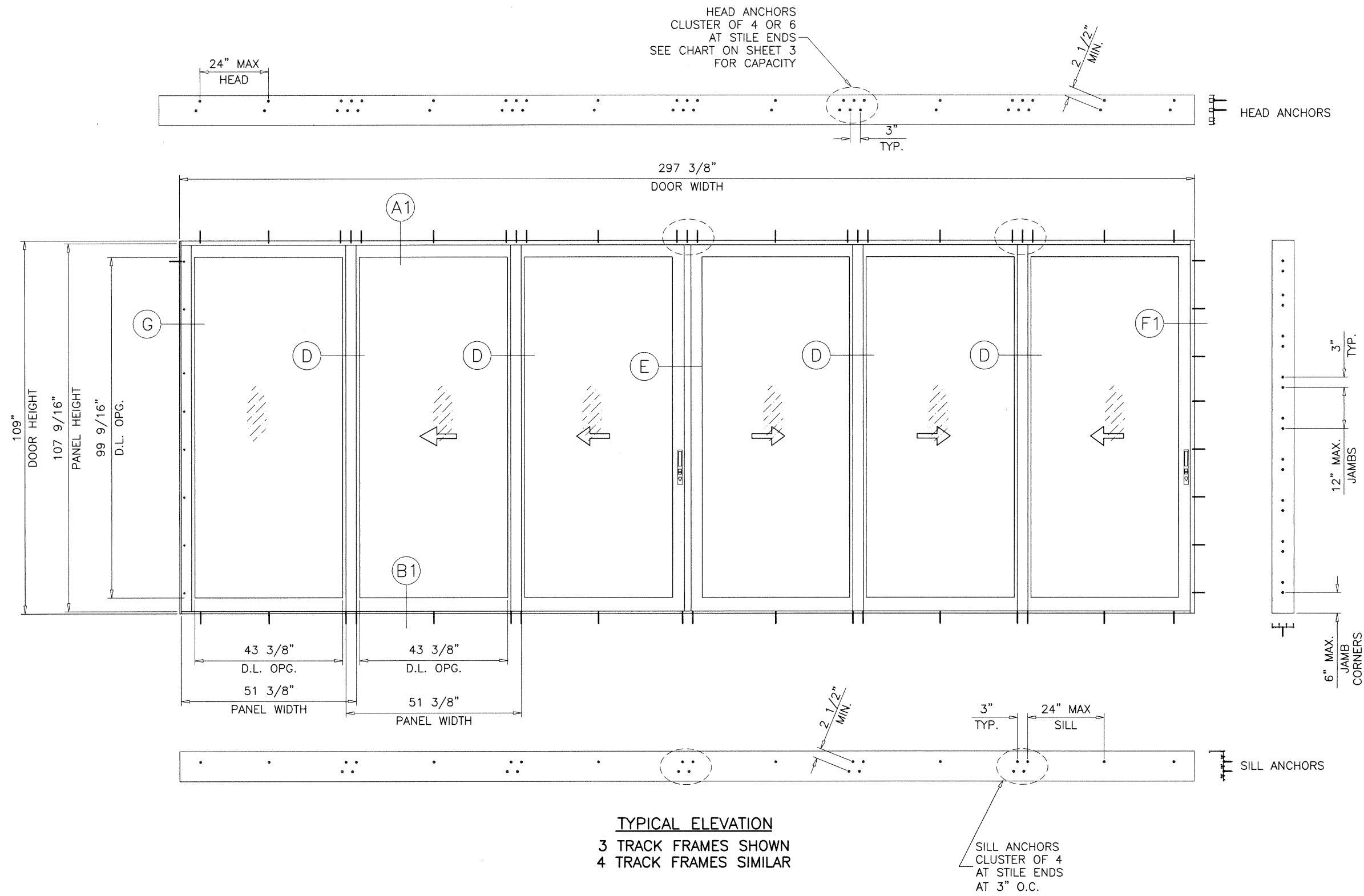

**TYPICAL ELEVATION**  
 3 TRACK FRAMES SHOWN  
 4 TRACK FRAMES SIMILAR

SILL ANCHORS CLUSTER OF 4 AT STILE ENDS AT 3" O.C.

**af c**

**AL-FAROOQ CORPORATION**  
 ENGINEERS & PRODUCT DEVELOPMENT  
 9360 SUNSET DRIVE, SUITE 220 (C.A.N. 3538)  
 MIAMI, FLORIDA 33173 TEL. (305) 264-8100 FAX. (305) 262-6978  
 COMP-ANL W12-31TMW

SERIES-390 ALUM. SLIDING GLASS DOOR (L.M.I.)

**Assura Windows & Doors, LLC.**  
 1543 N. Powerline Road  
 Pompano Beach, Fl. 33069  
 Tel. (305) 887-2646 Fax. (-)

no	date	by	description

FL #21848

**JALAL FAROOQ**  
 LICENSE  
 No. 81223  
 STATE OF FLORIDA  
 PROFESSIONAL ENGINEER

10/15/2020

date: 06-15-12	scale: 3/8"=1'-0"	dr. by: TARIQ	chk. by:
drawing no. W12-31			
sheet 2 of 13			

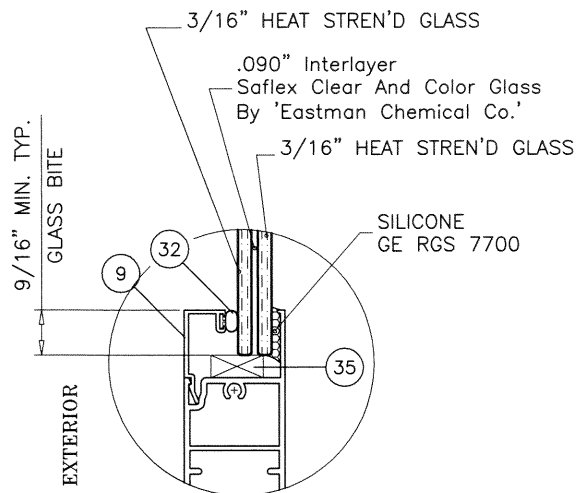

**GLASS TYPE 'G1'**

7/16" OVERALL LAMINATED GLASS

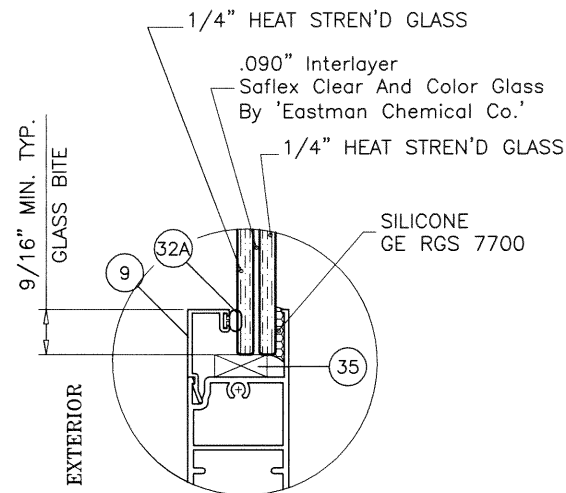

**GLASS TYPE 'G2'**

9/16" OVERALL LAMINATED GLASS

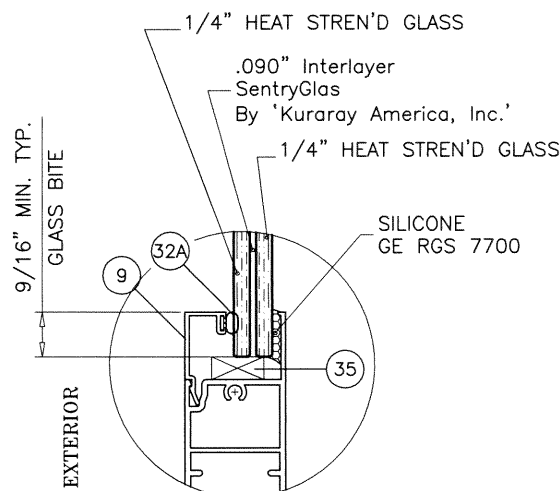

**GLASS TYPE 'G3'**

9/16" OVERALL LAMINATED GLASS

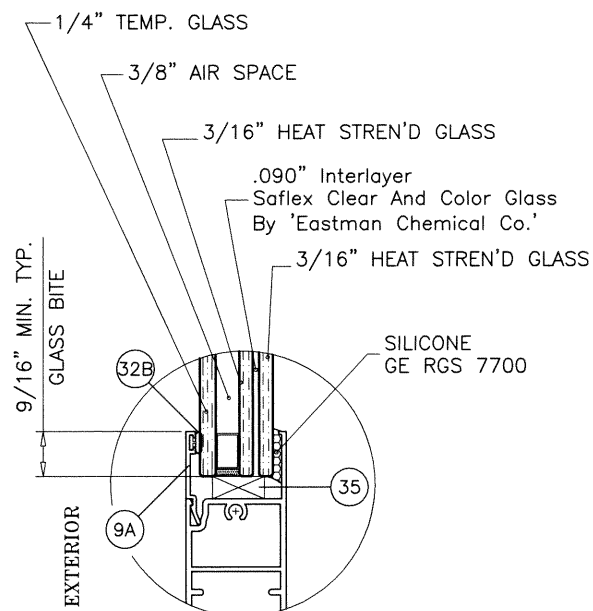

**GLASS TYPE 'G4'**

1-1/16" OVERALL INSUL. LAM. GLASS

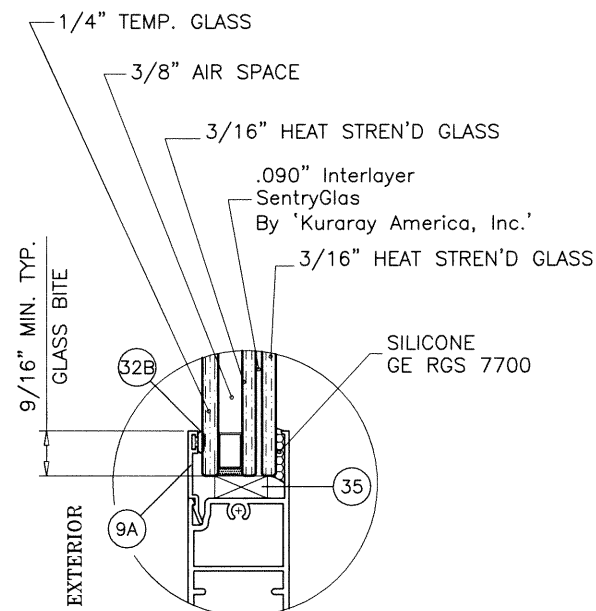

**GLASS TYPE 'G5'**

1-1/16" OVERALL INSUL. LAM. GLASS

		DESIGN LOAD CAPACITY - PSF							
AVERAGE PANEL WIDTH INCHES	DOOR HEIGHT INCHES	LIGHT REINF.		HEAVY REINF.					
		GLASS 'G1', 'G2' & 'G4'		GLASS 'G1', 'G2' & 'G4'		GLASS 'G3' & 'G5'			
		CLUSTER OF 4 ANCHORS AT STILE ENDS		CLUSTER OF 4 ANCHORS AT STILE ENDS		CLUSTER OF 4 ANCHORS AT STILE ENDS		CLUSTER OF 6 ANCHORS AT STILE ENDS	
		EXT.(+)	INT.(-)	EXT.(+)	INT.(-)	EXT.(+)	INT.(-)	EXT.(+)	INT.(-)
36	80	60.0	60.0	60.0	60.0	80.0	95.0	80.0	95.0
42		60.0	60.0	60.0	60.0	80.0	95.0	80.0	95.0
48		60.0	60.0	60.0	60.0	80.0	95.0	80.0	95.0
54		60.0	60.0	60.0	60.0	80.0	95.0	80.0	95.0
60		60.0	60.0	60.0	60.0	80.0	90.6	80.0	95.0
66		60.0	60.0	60.0	60.0	80.0	87.6	80.0	95.0
36	84	60.0	60.0	60.0	60.0	80.0	95.0	80.0	95.0
42		60.0	60.0	60.0	60.0	80.0	95.0	80.0	95.0
48		60.0	60.0	60.0	60.0	80.0	94.4	80.0	95.0
54		60.0	60.0	60.0	60.0	80.0	88.3	80.0	95.0
60		60.0	60.0	60.0	60.0	80.0	83.9	80.0	95.0
36	90	60.0	60.0	60.0	60.0	80.0	95.0	80.0	95.0
42		60.0	60.0	60.0	60.0	80.0	93.8	80.0	95.0
48		60.0	60.0	60.0	60.0	80.0	85.8	80.0	95.0
54		60.0	60.0	60.0	60.0	79.9	79.9	80.0	95.0
36	98	60.0	60.0	60.0	60.0	80.0	94.4	80.0	95.0
42		60.0	60.0	60.0	60.0	80.0	84.1	80.0	95.0
48		60.0	60.0	60.0	60.0	76.5	76.5	80.0	95.0
54		60.0	60.0	60.0	60.0	70.9	70.9	80.0	95.0
36	102	-	-	60.0	60.0	60.0	60.0	60.0	60.0
42		-	-	60.0	60.0	60.0	60.0	60.0	60.0
48		-	-	60.0	60.0	60.0	60.0	60.0	60.0
36	108	-	-	60.0	60.0	60.0	60.0	60.0	60.0
42		-	-	60.0	60.0	60.0	60.0	60.0	60.0
48		-	-	60.0	60.0	60.0	60.0	60.0	60.0

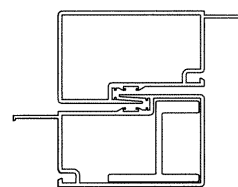

LIGHT REINF.

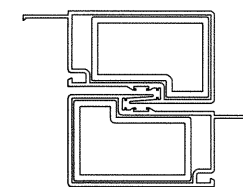

HEAVY REINF.

\* CLUSTER OF 6 APPLICABLE AT HEAD ONLY  
CLUSTER OF 4 TYPICAL AT SILL

$$\text{AVERAGE PANEL WIDTH} = \frac{\text{DOOR WIDTH}}{\text{NUMBER OF PANELS}}$$

ALL EXTERIOR(+) LOADS SHOWN IN CHARTS ABOVE ARE FOR DOORS WITH 3-1/2" SILL HEIGHTS. FOR 2-3/4" SILL HEIGHT LIMIT EXT.(+) LOADS TO 60.0 PSF FOR 1-3/4" SILL HEIGHT LIMIT EXT.(+) LOADS TO 34.7 PSF SEE SHEET 4 FOR DETAILS

NOTE: GLASS CAPACITIES ON THIS SHEET ARE BASED ON ASTM E1300-09 (3 SEC. GUSTS) AND FLORIDA BUILDING COMMISSION DECLARATORY STATEMENT DCA05-DEC-219

10/15/2020

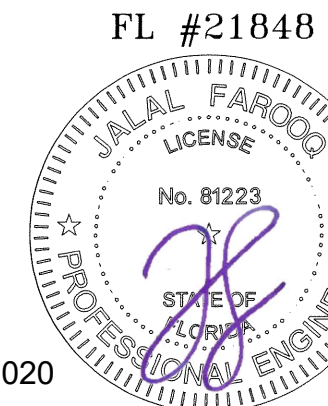

**af c**  
AL-FAROOQ CORPORATION  
ENGINEERS & PRODUCT DEVELOPMENT  
9360 SUNSET DRIVE, SUITE 220 (C.A.N. 3538)  
MIAMI, FLORIDA 33173  
TEL. (305) 264-8100 FAX. (305) 262-6978  
COMP-ANL\W12-31TMW

SERIES-390 ALUM. SLIDING GLASS DOOR (L.M.I.)  
**Assura Windows & Doors, LLC.**  
1543 N. Powerline Road  
Pompano Beach, FL 33069  
Tel. (305) 887-2646 Fax. (-)

revisions:	no	date	by	description
date:	06-15-12	scale:	3/8" = 1"	
dr. by:	TARIQ	chk. by:		
drawing no.	W12-31			
sheet	3 of 13			



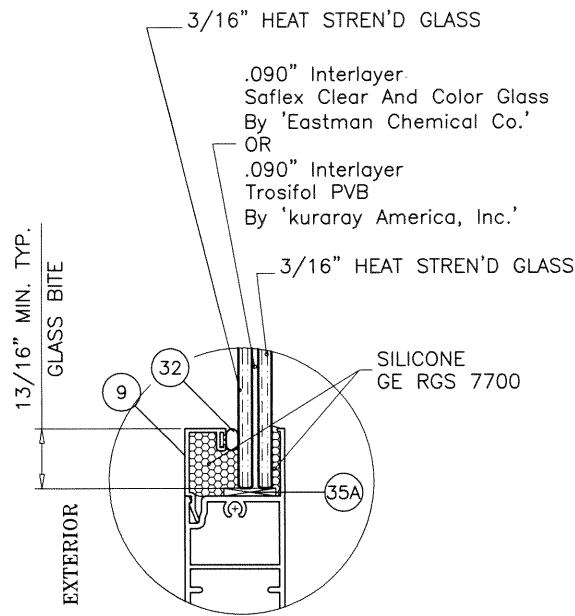

**GLASS TYPE 'G6'**

7/16" OVERALL LAMINATED GLASS

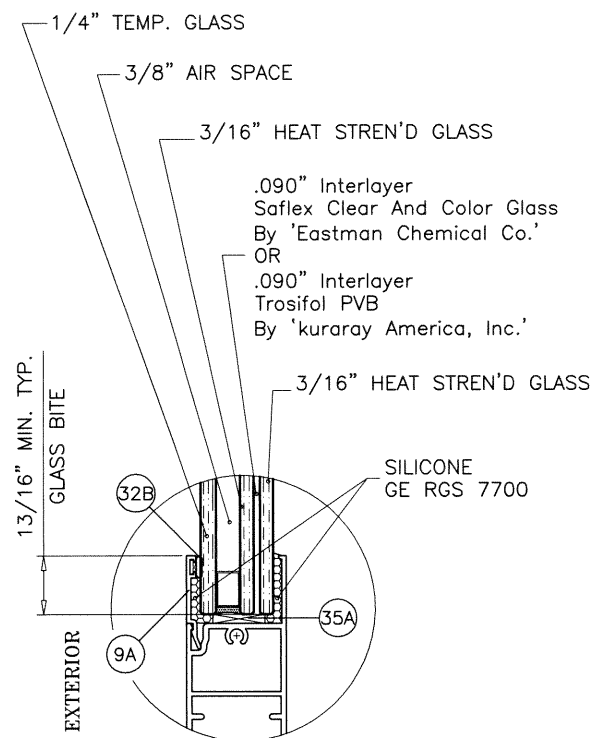

**GLASS TYPE 'G6A'**

1-1/16" OVERALL INSUL. LAM. GLASS

DESIGN LOAD CAPACITY - PSF			
AVERAGE PANEL WIDTH INCHES	DOOR HEIGHT INCHES	LIGHT REINF.	
		GLASS 'G6' & 'G6A'	
		CLUSTER OF 4 ANCHORS AT STILE ENDS	
		EXT.(+)	INT.(-)
36	80	70.0	70.0
		70.0	70.0
		70.0	70.0
		70.0	70.0
36	84	70.0	70.0
		70.0	70.0
		70.0	70.0
		70.0	70.0
36	90	70.0	70.0
		70.0	70.0
		70.0	70.0
36	98	70.0	70.0
		70.0	70.0
		70.0	70.0

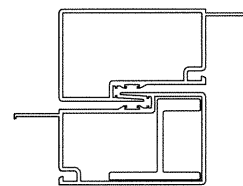

LIGHT REINF.

$$\text{AVERAGE PANEL WIDTH} = \frac{\text{DOOR WIDTH}}{\text{NUMBER OF PANELS}}$$

ALL EXTERIOR(+) LOADS SHOWN IN CHARTS ABOVE ARE FOR DOORS WITH 3-1/2" SILL HEIGHTS.  
 FOR 2-3/4" SILL HEIGHT LIMIT EXT.(+) LOADS TO 60.0 PSF  
 FOR 1-3/4" SILL HEIGHT LIMIT EXT.(+) LOADS TO 34.7 PSF  
 SEE SHEET 4 FOR DETAILS

NOTE:  
 GLASS CAPACITIES ON THIS SHEET ARE  
 BASED ON ASTM E1300-09 (3 SEC. GUSTS)  
 AND FLORIDA BUILDING COMMISSION  
 DECLARATORY STATEMENT DCA05-DEC-219



10/15/2020

**af c**  
**AL-FAROOQ CORPORATION**  
 ENGINEERS & PRODUCT DEVELOPMENT  
 9360 SUNSET DRIVE, SUITE 220 (C.A.N. 3538)  
 MIAMI, FLORIDA 33173  
 TEL. (305) 264-8100 FAX. (305) 262-6978  
 COMP-ANL \ W12-31TMW

SERIES-390 ALUM. SLIDING GLASS DOOR (L.M.I.)  
**Assura Windows & Doors, LLC.**  
 1543 N. Powerline Road  
 Pompano Beach, Fl. 33069  
 Tel. (305) 887-2646 Fax. (-)

revisions:	no	date	by	description

date: 06-15-12	scale: 3/8" = 1"
dr. by: TARIQ	chk. by:

drawing no.  
**W12-31**  
 sheet 3.1 of 13

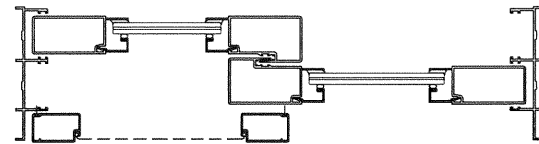
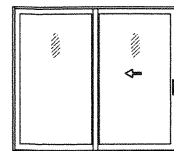

OX (SHOWN)  
XO  
XX

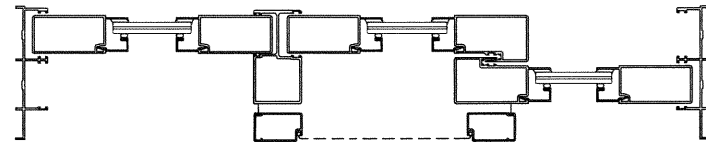
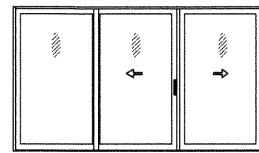

O XO (SHOWN)  
OXX  
XXO

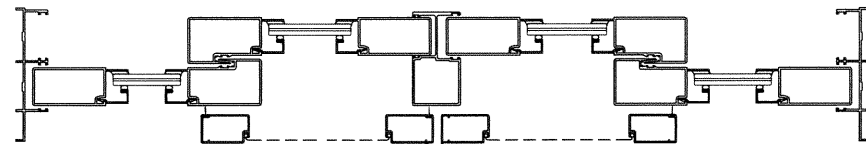
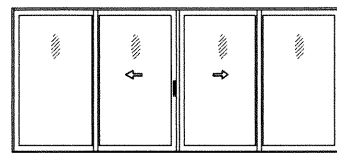

OXXO (SHOWN)  
OXXX  
XXXX

APPROVED CONFIGURATIONS  
NON-POCKETED DOORS

TWO (2) TRACK FRAMES

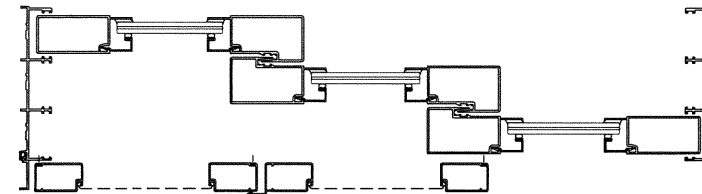
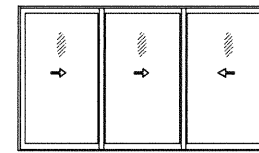

XXX (SHOWN)  
OXX  
XXO

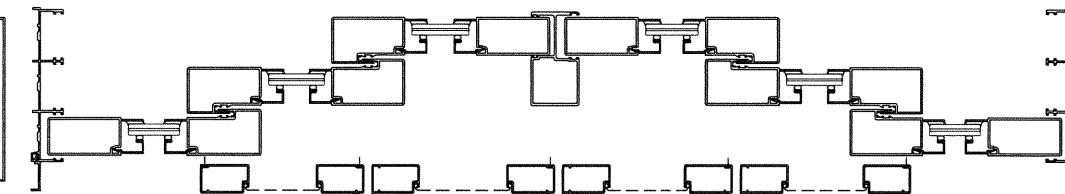
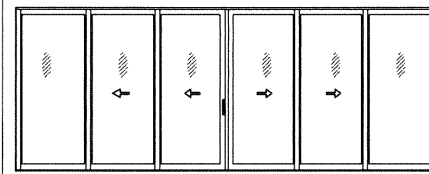

OXXXXO (SHOWN)  
XXXXXX

APPROVED CONFIGURATIONS  
NON-POCKETED DOORS

THREE (3) TRACK FRAMES

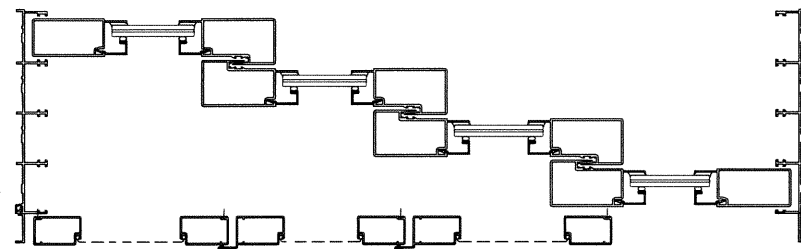
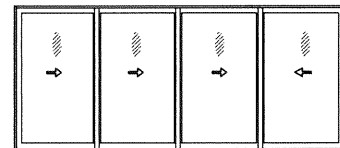

XXXX (SHOWN)  
OXXX  
XXXO

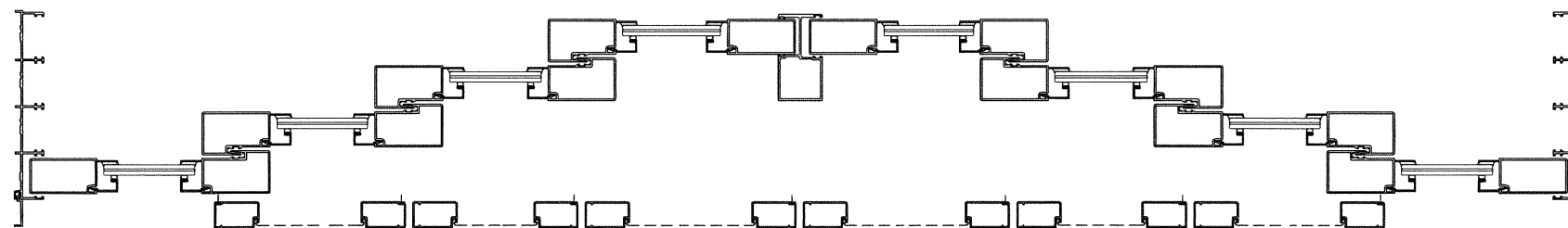
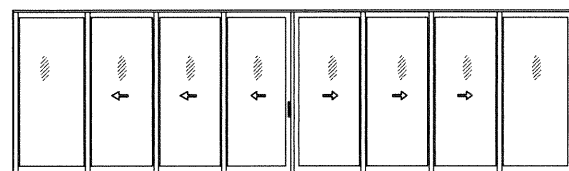

OXXXXXXO (SHOWN)  
XXXXXXXX

APPROVED CONFIGURATIONS  
NON-POCKETED DOORS

FOUR (4) TRACK FRAMES

10/15/2020



**afc**  
**AL-FAROOQ CORPORATION**  
ENGINEERS & PRODUCT DEVELOPMENT  
9360 SUNSET DRIVE, SUITE 220 (C.A.N. 3538)  
MIAMI, FLORIDA 33173  
TEL. (305) 264-8100 FAX. (305) 262-6978  
COMP-ANL\W12-31TMW

SERIES-390 ALUM. SLIDING GLASS DOOR (L.M.I.)  
**Assura Windows & Doors, LLC.**  
1543 N. Powerline Road  
Pompano Beach, FL 33069  
Tel. (305) 887-2646 Fax. (-)

no	date	by	description

date: 06-15-12  
scale: 3/8"=1'-0"  
dr. by: TARIQ  
chk. by:

drawing no.  
**W12-31**  
sheet 4 of 13

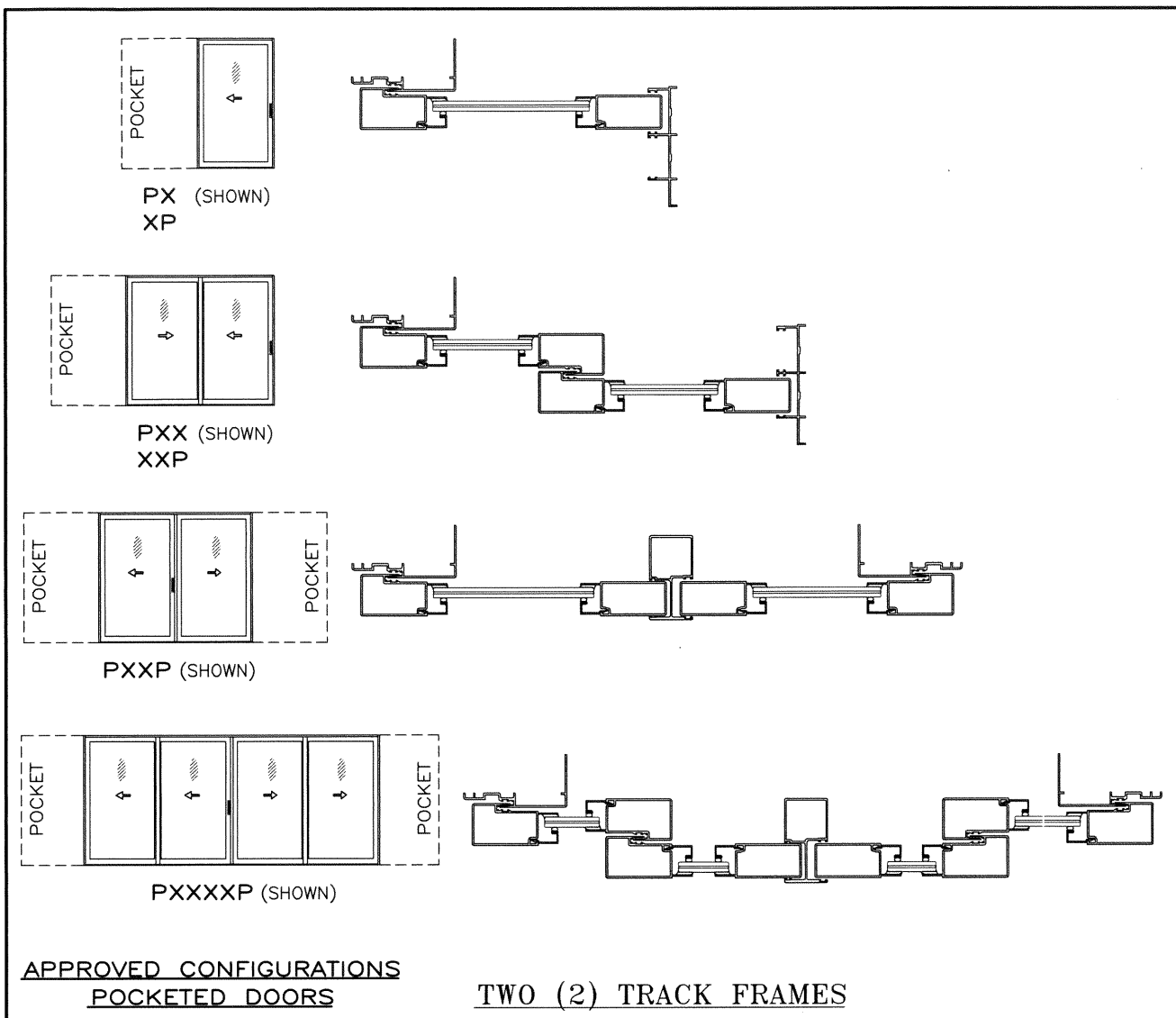

APPROVED CONFIGURATIONS  
POCKETED DOORS TWO (2) TRACK FRAMES

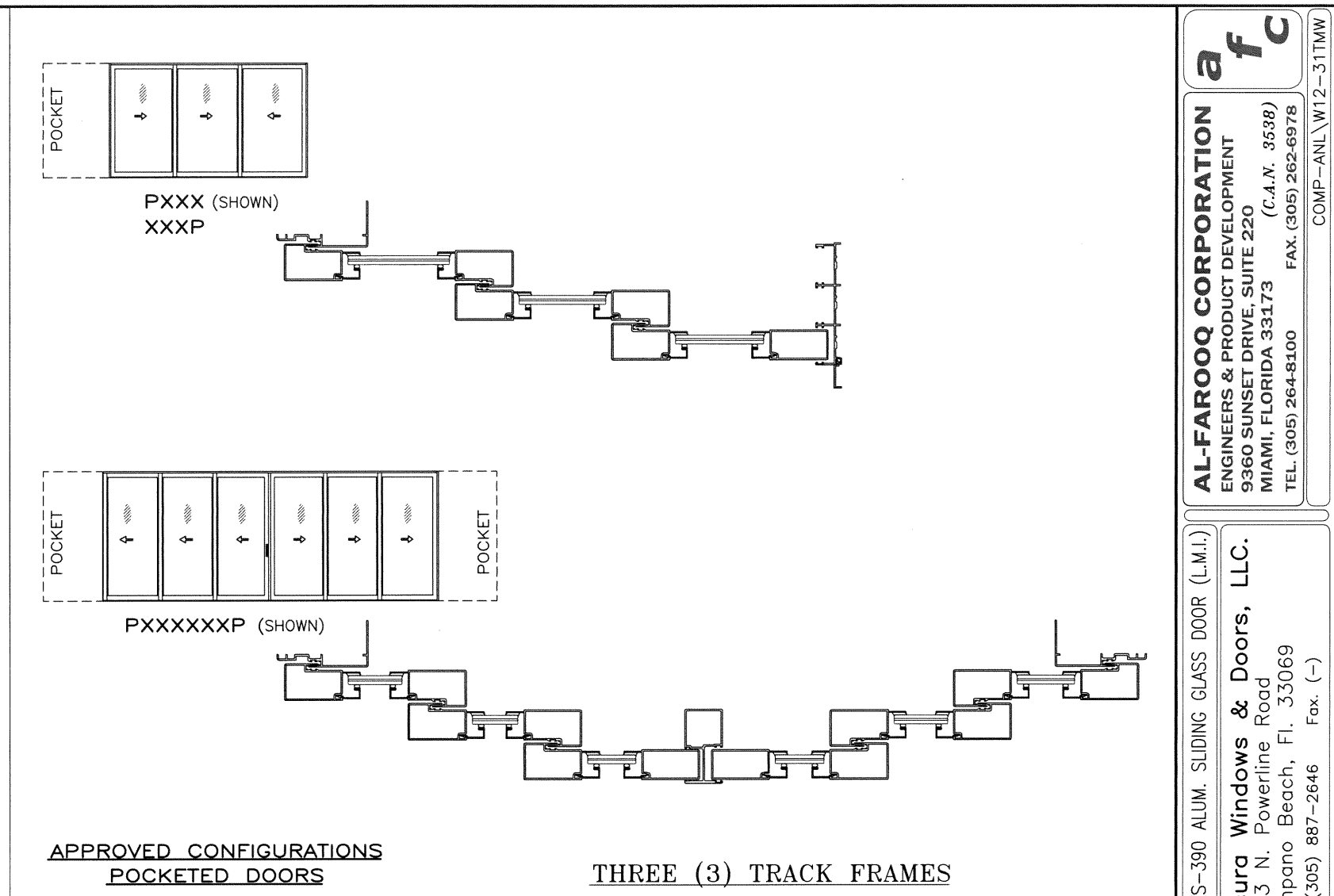

APPROVED CONFIGURATIONS  
POCKETED DOORS THREE (3) TRACK FRAMES

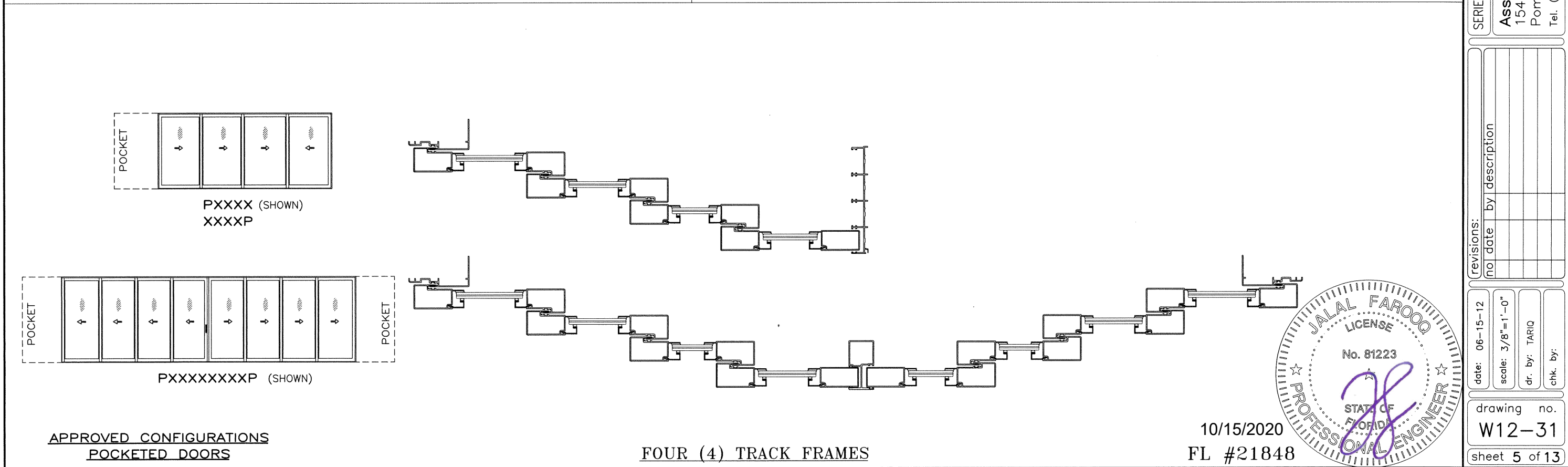

APPROVED CONFIGURATIONS  
POCKETED DOORS FOUR (4) TRACK FRAMES

10/15/2020  
FL #21848



**af c**  
**AL-FAROOQ CORPORATION**  
ENGINEERS & PRODUCT DEVELOPMENT  
9360 SUNSET DRIVE, SUITE 220 (C.A.N. 3538)  
MIAMI, FLORIDA 33173  
TEL. (305) 264-8100 FAX. (305) 262-6978  
COMP-ANL\W12-31TMW

SERIES-390 ALUM. SLIDING GLASS DOOR (L.M.I.)  
**Assura Windows & Doors, LLC.**  
1543 N. Powerline Road  
Pompano Beach, Fl. 33069  
Tel. (305) 887-2646 Fax. (-)

revisions:	
no	description

date: 06-15-12	scale: 3/8"=1'-0"	dr. by: TARIQ	chk. by:
drawing no. <b>W12-31</b>		sheet 5 of 13	



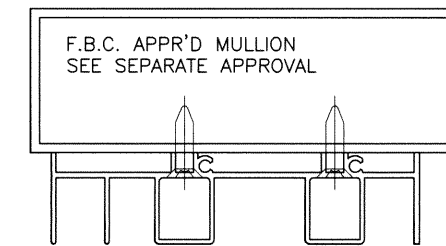
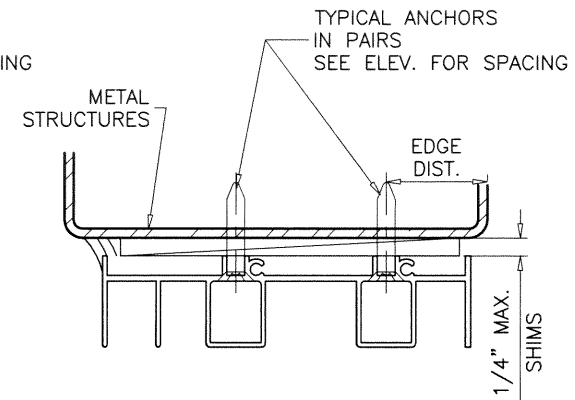
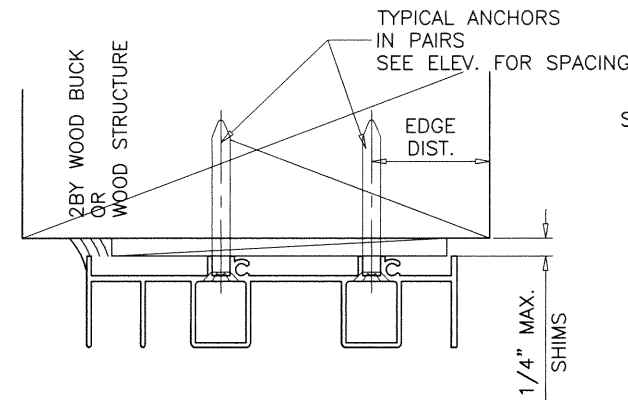
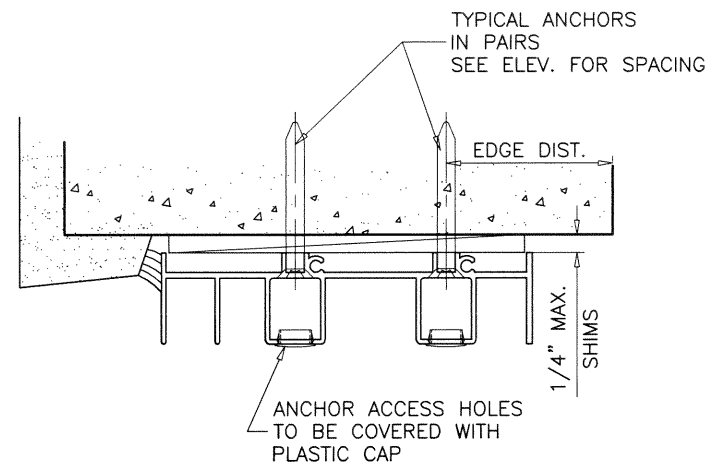
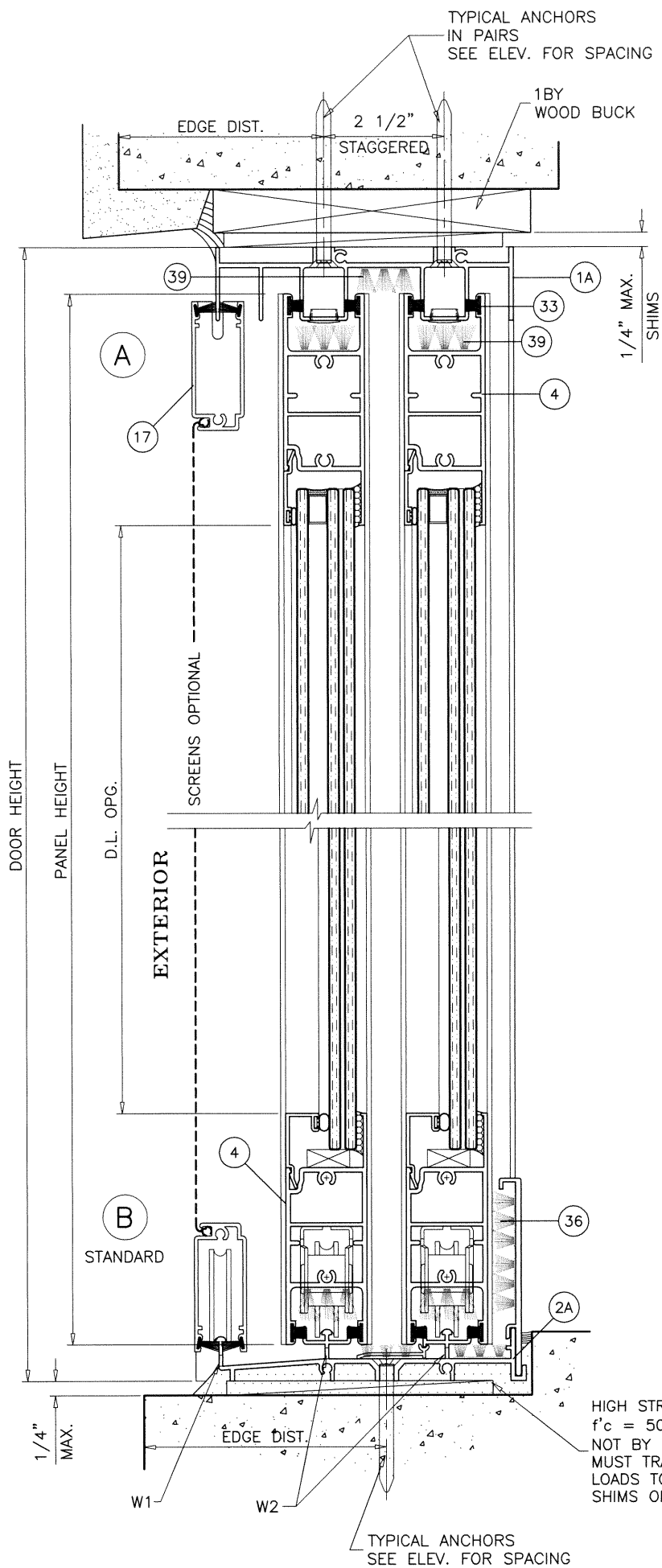

WOOD BUCKS AND METAL STRUCTURE NOT BY 'ASSURA WDW.' MUST SUSTAIN LOADS IMPOSED BY GLAZING SYSTEM AND TRANSFER THEM TO THE BUILDING STRUCTURE.

**TYPICAL ANCHORS:** SEE ELEV. FOR SPACING  
**1/4" DIA. ULTRACON+ BY 'DEWALT'** (Fu=164 KSI, Fy=148 KSI)  
 INTO 2BY WOOD BUCKS OR WOOD STRUCTURES  
 1-1/2" MIN. PENETRATION INTO WOOD (HEAD/JAMBS)  
 THRU 1BY BUCKS INTO CONC. OR BLOCKS  
 1-3/8" MIN. EMBED INTO CONCRETE (HEAD/JAMBS)  
 1-3/8" MIN. EMBED INTO GROUT-FILLED BLOCKS (JAMBS)  
 DIRECTLY INTO CONCRETE OR BLOCKS  
 1-3/8" MIN. EMBED INTO CONCRETE (HEAD/SILL/JAMBS)  
 1-3/8" MIN. EMBED INTO GROUT-FILLED BLOCKS (JAMBS)

**#14 SMS OR SELF-DRILLING SCREWS** (GRADE 2 CRS)  
 INTO F.B.C. APPROVED MULLIONS  
 OR  
 INTO METAL STRUCTURES (HEAD/SILL/JAMBS)  
 (3) THREADS MIN. TO EXTEND BEYOND METAL THICKNESS  
 ALUMINUM: 1/8" THK. MIN. (6063-T5 MIN.)  
 STEEL: 1/8" THK. MIN. (Fy = 36 KSI MIN.)  
 (STEEL IN CONTACT WITH ALUMINUM TO BE PLATED OR PAINTED)

**CRITICAL EDGE DISTANCE**  
 INTO CONCRETE AND BLOCKS = 2-1/2" MIN.  
 INTO WOOD STRUCTURE = 1" MIN.  
 INTO METAL STRUCTURE = 3/4" MIN.

WOOD AT HEAD OR JAMBS SG = 0.55 MIN.  
 CONCRETE AT HEAD, SILL OR JAMBS f'c = 3000 PSI MIN.  
 C-90 HOLLOW/FILLED BLOCK AT JAMBS f'm = 2000 PSI MIN.

**WEEPHOLES:**  
 W1 = (2) 5/16" X 3/8" WEEP NOTCH AT EACH END OF SILL  
 W2 = (2) 3/16" X 3/4" WEEP NOTCH AT EACH END OF SILL

**a f c**  
**AL-FAROOQ CORPORATION**  
 ENGINEERS & PRODUCT DEVELOPMENT  
 9360 SUNSET DRIVE, SUITE 220  
 MIAMI, FLORIDA 33173  
 TEL. (305) 264-8100 FAX. (305) 262-6978  
 (C.A.N. 3538)

SERIES-390 ALUM. SLIDING GLASS DOOR (L.M.I.)  
**Assura Windows & Doors, LLC.**  
 1543 N. Powerline Road  
 Pompano Beach, Fl. 33069  
 Tel. (305) 887-2646 Fax. (-)

no	date	by description

date: 06-15-12  
 scale: 3/8" = 1"  
 dr. by: TARIQ  
 chk. by:

drawing no.  
**W12-31**  
 sheet 6 of 13

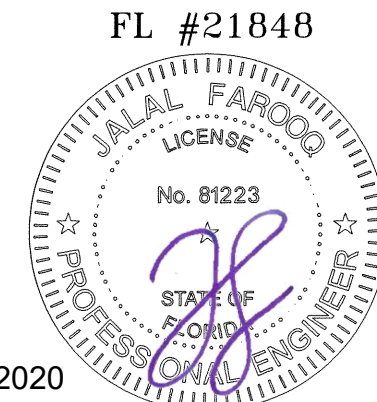

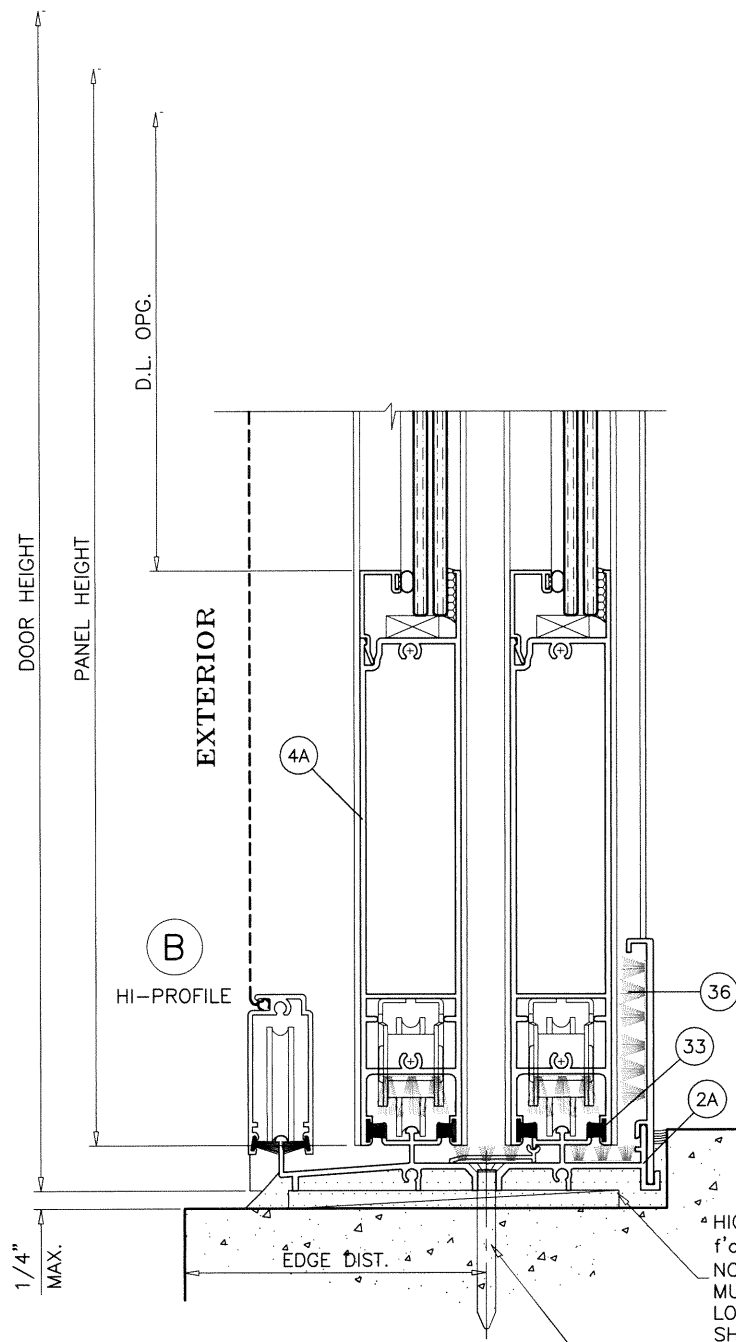

\* HIGH STRENGTH GROUT  
 f'c = 5000 PSI MIN.  
 NOT BY 'ASSURA WDW.'  
 MUST TRANSFER SHEAR  
 LOADS TO STRUCTURE  
 SHIMS OPTIONAL

TYPICAL ANCHORS  
 SEE ELEV. FOR SPACING

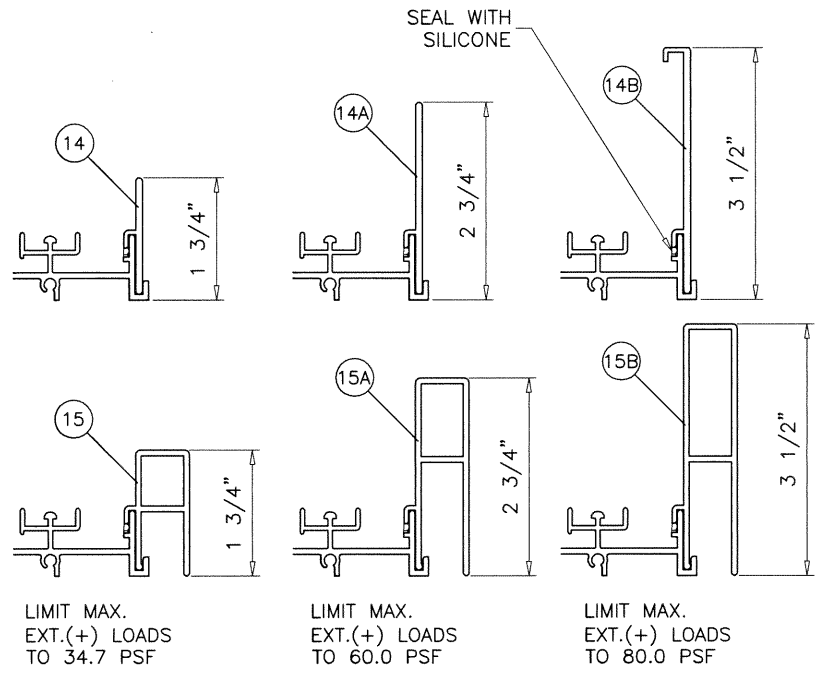

LIMIT MAX.  
 EXT.(+) LOADS  
 TO 34.7 PSF

LIMIT MAX.  
 EXT.(+) LOADS  
 TO 60.0 PSF

LIMIT MAX.  
 EXT.(+) LOADS  
 TO 80.0 PSF

TWO (2) TRACK DOOR DETAILS

10/15/2020

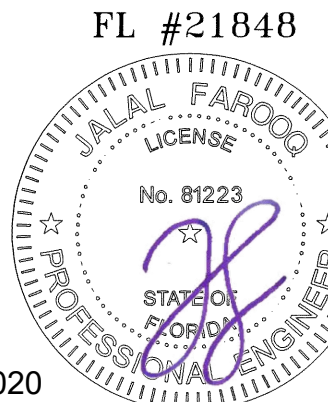

SERIES-390 ALUM. SLIDING GLASS DOOR (L.M.I.)

**Assura Windows & Doors, LLC.**  
 1543 N. Powerline Road  
 Pompano Beach, FL 33069  
 Tel. (305) 887-2646 Fax. (-)

no	date	by	description

date: 06-15-12  
 scale: 3/8" = 1"  
 dr. by: TARIQ  
 chk. by:

drawing no.  
**W12-31**  
 sheet 7 of 13

**af c**  
**AL-FAROOQ CORPORATION**  
 ENGINEERS & PRODUCT DEVELOPMENT  
 9360 SUNSET DRIVE, SUITE 220  
 MIAMI, FLORIDA 33173 (C.A.N. 3538)  
 TEL. (305) 264-8100 FAX. (305) 262-6978  
 COMP-ANL\W12-31TMW



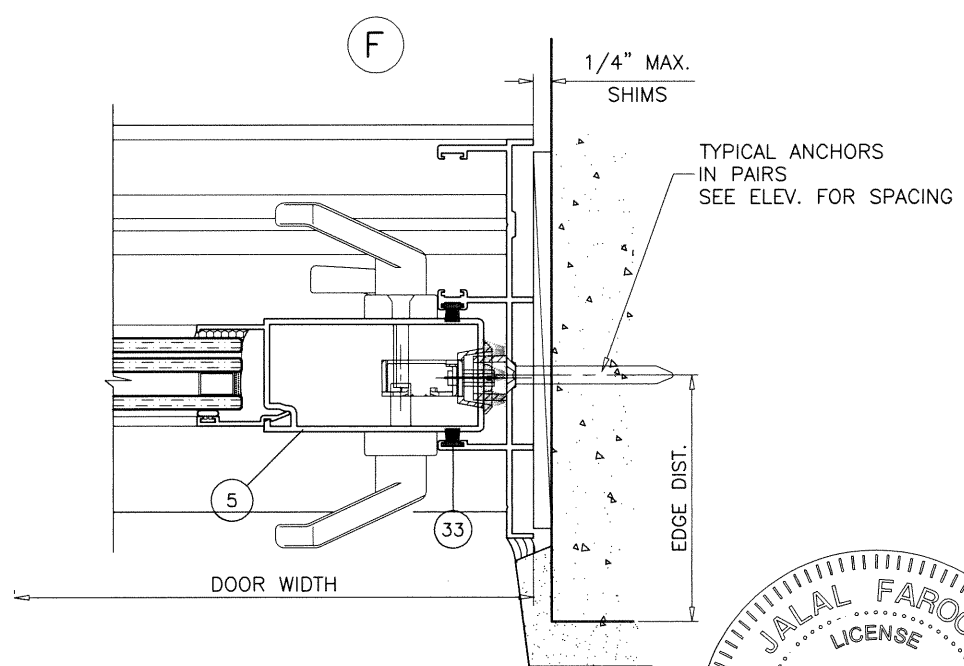
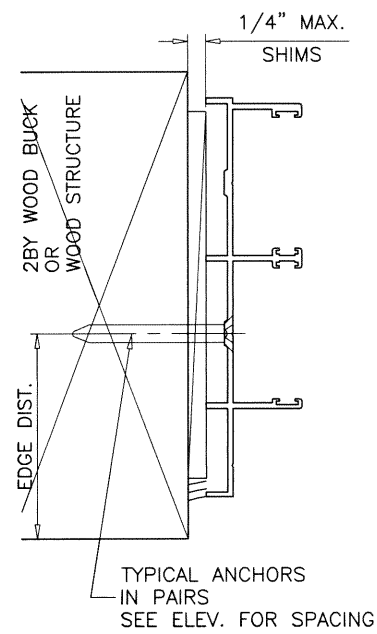
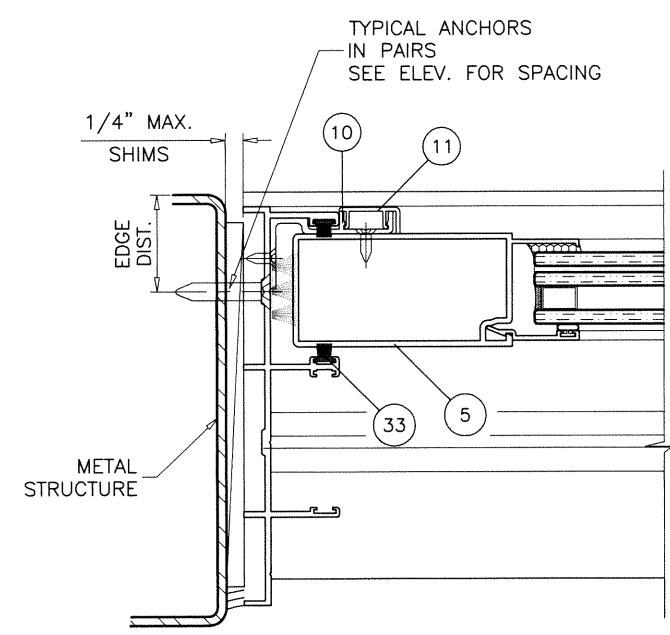
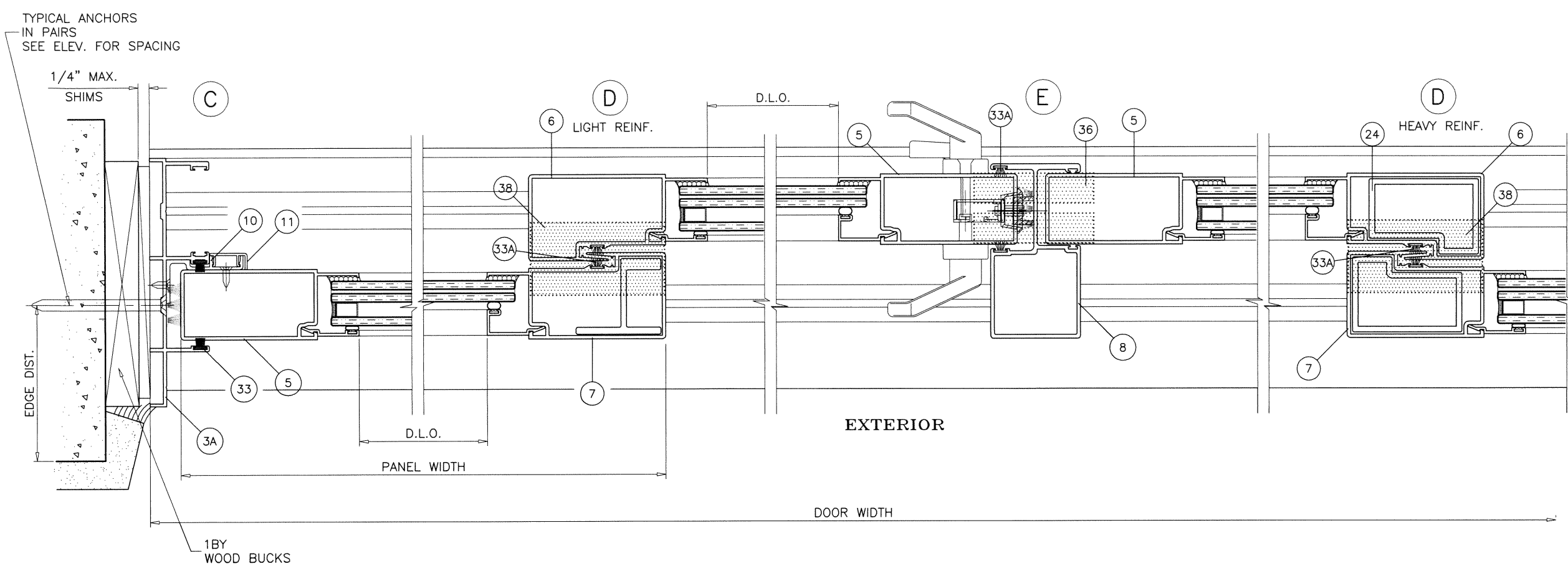

TWO (2) TRACK DOOR DETAILS

10/15/2020.  
FL #21848

**af c**  
**AL-FAROOQ CORPORATION**  
ENGINEERS & PRODUCT DEVELOPMENT  
9360 SUNSET DRIVE, SUITE 220  
MIAMI, FLORIDA 33173 (C.A.N. 5538)  
TEL. (305) 264-8100 FAX. (305) 262-6978  
COMP-ANL\W12-31TMW

SERIES-390 ALUM. SLIDING GLASS DOOR (L.M.I.)  
**Assura Windows & Doors, LLC.**  
1543 N. Powerline Road  
Pompano Beach, Fl. 33069  
Tel. (305) 887-2646 Fax. (-)

no	date	description

date: 06-15-12  
scale: 3/8" = 1"  
dr. by: TARIQ  
chk. by:

drawing no.  
**W12-31**  
sheet 8 of 13

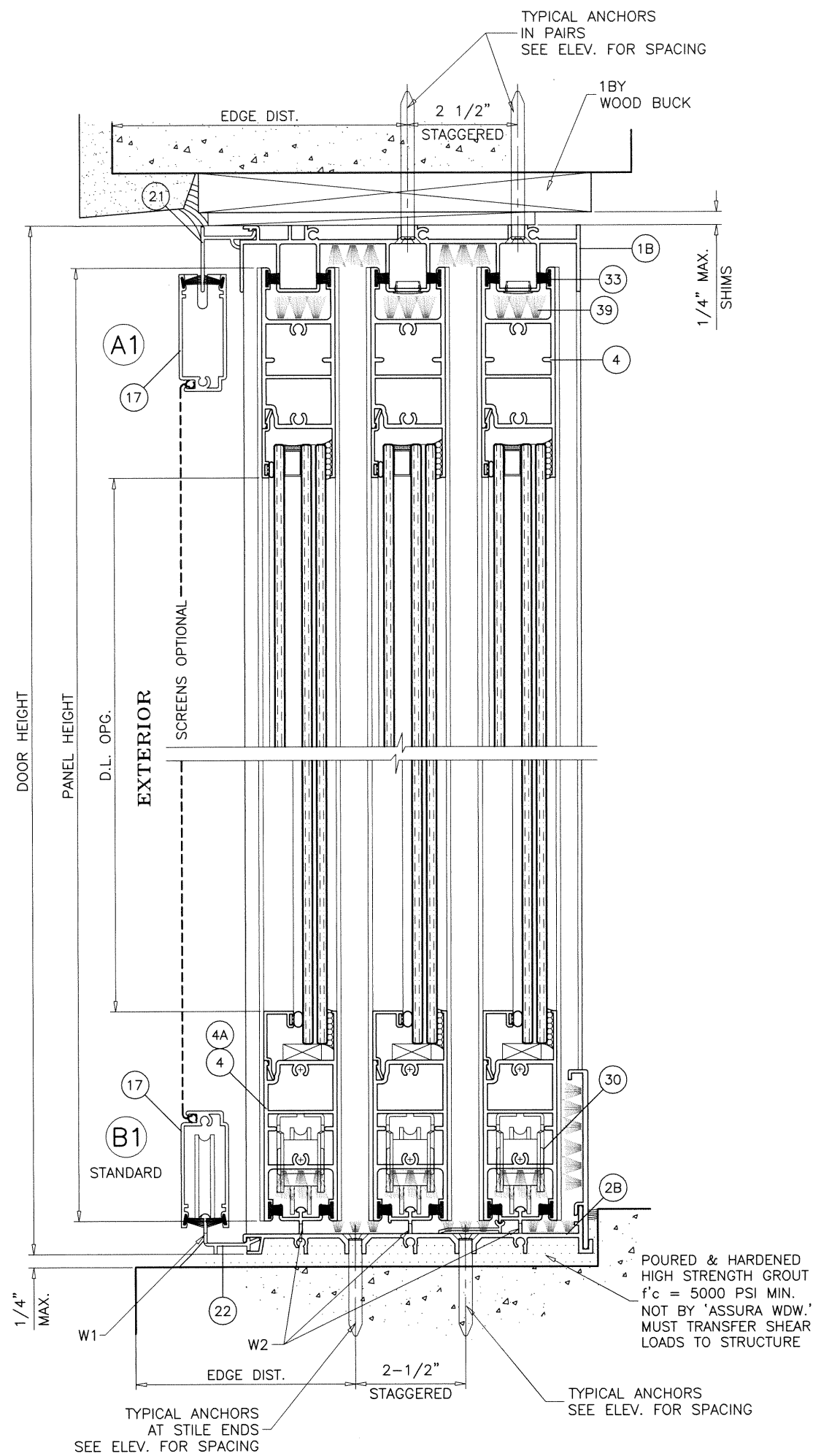

**WEEPHOLES:**

- W1 = (2) 5/16" X 3/8" WEEP NOTCH AT EACH END OF SILL
- W2 = (2) 3/16" X 3/4" WEEP NOTCH AT EACH END OF SILL

**THREE (3) TRACK DOOR DETAILS**  
**FOUR (4) TRACK DOOR SIMILAR**

10/15/2020



FL #21848

SERIES-390 ALUM. SLIDING GLASS DOOR (L.M.I.)  
**Assura Windows & Doors, LLC.**  
 1543 N. Powerline Road  
 Pompano Beach, Fl. 33069  
 Tel. (305) 887-2646 Fax. (-)

**AL-FAROOQ CORPORATION**  
 ENGINEERS & PRODUCT DEVELOPMENT  
 9360 SUNSET DRIVE, SUITE 220  
 MIAMI, FLORIDA 33173 (C.A.N. 5538)  
 TEL. (305) 264-8100 FAX. (305) 262-6978  
 COMP-ANL\W12-31TMW

no	date	by	description

date: 06-15-12  
 scale: 3/8" = 1"  
 dr. by: TARIQ  
 chk. by:   
 drawing no. **W12-31**  
 sheet 9 of 13

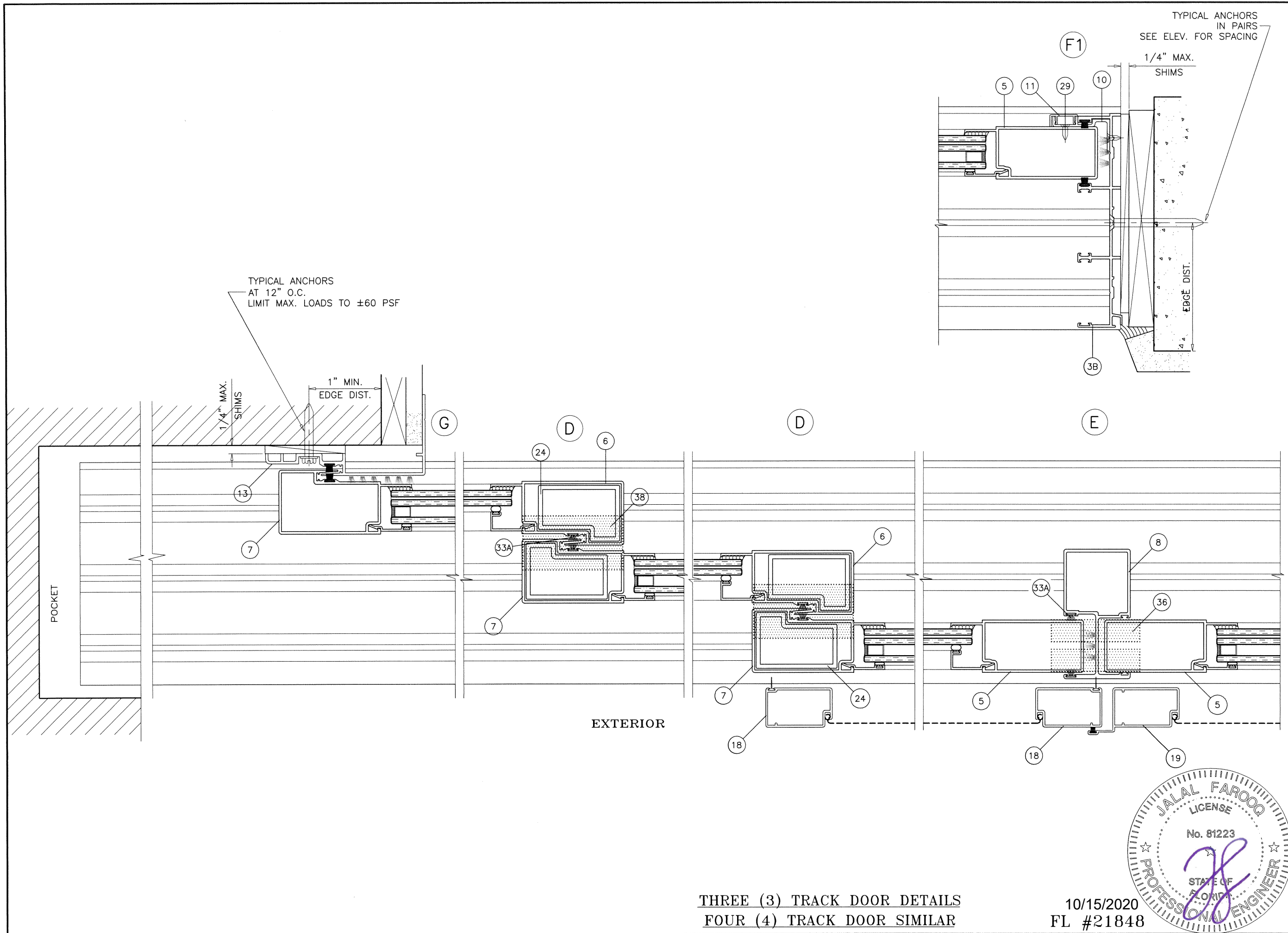

**af c**  
**AL-FAROOQ CORPORATION**  
 ENGINEERS & PRODUCT DEVELOPMENT  
 9360 SUNSET DRIVE, SUITE 220  
 MIAMI, FLORIDA 33173 (C.A.N. 3538)  
 TEL. (305) 264-8100 FAX. (305) 262-6978  
 COMP-ANL W12-31TMW

SERIES-390 ALUM. SLIDING GLASS DOOR (L.M.I.)  
**Assura Windows & Doors, LLC.**  
 1543 N. Powerline Road  
 Pompano Beach, Fl. 33069  
 Tel. (305) 887-2646 Fax. (-)

no	date	by	description

date: 06-15-12  
 scale: 3/8" = 1"  
 dr. by: TARIQ  
 chk. by:

drawing no.  
**W12-31**  
 sheet 10 of 13

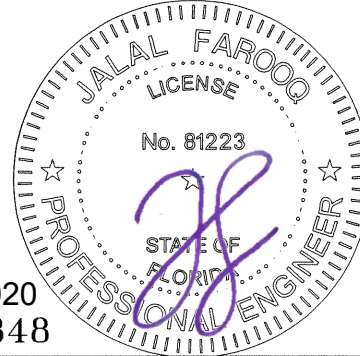

THREE (3) TRACK DOOR DETAILS  
 FOUR (4) TRACK DOOR SIMILAR

10/15/2020  
 FL #21848



ITEM	PART #	QUANTITY	DESCRIPTION	MATERIAL	MANF./SUPPLIER/REMARKS
1A	TM-347	1	2 TRACK FRAME HEAD	6063-T6	-
1B	TM-333	1	3 TRACK FRAME HEAD	6063-T6	-
1C	TM-336	1	4 TRACK FRAME HEAD	6063-T6	-
2A	TM-331	1	2 TRACK FRAME SILL	6063-T6	-
2B	TM-334	1	3 TRACK FRAME SILL	6063-T6	-
2C	TM-337	1	4 TRACK FRAME SILL	6063-T6	-
3A	TM-332	2	2 TRACK FRAME JAMB	6063-T6	-
3B	TM-335	2	3 TRACK FRAME JAMB	6063-T6	-
3C	TM-338	2	4 TRACK FRAME JAMB	6063-T6	-
4	TM-321	2/ PANEL	PANEL TOP AND BOTTOM RAIL	6063-T6	-
4A	TM-330	1/ PANEL	PANEL BOTTOM RAIL (HIGH PROFILE)	6063-T6	-
5	TM-322	1	PANEL JAMB STILE	6063-T6	-
6	TM-323	AS REQD.	STD. INNER INTERLOCK	6063-T6	-
7	TM-324	AS REQD.	STD. OUTER INTERLOCK	6063-T6	-
8	TM-325	AS REQD.	ASTRAGAL STILE	6063-T6	-
9	TM-327	4/ PANEL	GLAZING BEAD (LAM. GLASS)	6063-T6	-
9A	TM-326	4/ PANEL	GLAZING BEAD (LAM. INSUL. GLASS)	6063-T6	-
10	TM-348	1/ FIX. PANEL	FIX. PANEL CLIP	6063-T6	-
11	TM-349	AS REQD.	FIX. PANEL CLIP COVER	6063-T6	-
12	TM-339	2	JAMB COVER	6063-T6	-
13	TM-347	AS REQD.	POCKET DOOR HOOK	6063-T6	-
14	TM-341	AS REQD.	2" SILL RISER	6063-T6	-
14A	TM-342	AS REQD.	2-3/4" SILL RISER	6063-T6	-
14B	TM-343	AS REQD.	3-1/2" SILL RISER	6063-T6	-
15A	TM-350	AS REQD.	2-3/4" SILL RISER	6063-T6	-
15B	TM-351	AS REQD.	3-1/2" SILL RISER	6063-T6	-
16	TM-340	AS REQD.	SILL ANCHOR COVER	6063-T6	-
17	TM-354	AS REQD.	SCREEN TOP & BOTTOM RAIL	6063-T6	-
18	TM-355	AS REQD.	SCREEN STILE	6063-T6	-
19	TM-357	AS REQD.	OXXO SCREEN STILE	6063-T6	-
20	TM-356	AS REQD.	OXO SCREEN ADAPTER	6063-T6	-
21	TM-344	AS REQD.	FRAME HEAD SCREEN ADAPTER (3 & 4 TRACKS)	6063-T6	-
22	TM-345	AS REQD.	FRAME SILL SCREEN ADAPTER (3 & 4 TRACKS)	6063-T6	-
23	TM-346	AS REQD.	FRAME JAMB SCREEN ADAPTER (3 & 4 TRACKS)	6063-T6	-
24	TM-328	AS REQD.	HOLLOW STIFFENER	6063-T6	-
25	TM-329	AS REQD.	SOLID STIFFENER	6063-T6	-
26	-	-	-	-	-
27	#10 X 3/4"	AS REQD.	FRAME ASSEMBLY SCREWS	ST. STEEL	PH P SMS
28	#12 X 1"	2/ CORNER	PANEL ASSEMBLY SCREWS	ST. STEEL	FH SMS
29	#10 X 1"	AS REQD.	FIX. PANEL SCREWS, AT 6" FROM ENDS & 24" O.C. MAX.	ST. STEEL	FPF SMS/TEKS
30	-	2/ PANEL	ROLLER ASSEMBLY	-	HSTD
31	-	-	MORTISE HOOK LOCK	-	FASCO
32	E70818KN1020	4/ LITE	GLAZING GASKET (7/16" LAM. GLASS)	VINYL	ULTRAFAB
32A	W32001	4/ LITE	GLAZING GASKET (9/16" LAM. GLASS)	VINYL	AMESBURY
32B	W32011	4/ LITE	GLAZING GASKET (INSUL. LAM. GLASS)	VINYL	AMESBURY
33	21315	AS REQD.	FIN SEAL PILE W'STRIPPING	-	ULTRAFAB
33A	33371	AS REQD.	FIN SEAL PILE W'STRIPPING	-	ULTRAFAB
34	-	AS REQD.	BULB W'STRIPPING	VINYL	-
35	-	2/ LITE	SETTING BLOCK, 5/16" X 1/2" X 2" LONG	EPDM	LAMATEK
35A	-	2/ LITE	SETTING BLOCK, 1/8" X 1/2" X 2" LONG	EPDM	LAMATEK
36	-	AS REQD.	SELF ADHESIVE PILE PAD (1-3/4" X 3" X 3/4")	WOOL	ULTRAFAB
37	-	AS REQD.	SELF ADHESIVE PILE PAD (1" X 2-7/16" X 1/2")	WOOL	ULTRAFAB
38	-	AS REQD.	SELF ADHESIVE PILE PAD (1-5/8" X 2-7/16" X 1/2")	WOOL	ULTRAFAB
39	-	AS REQD.	SELF ADHESIVE PILE PAD (1/8" X 2-7/16" X 3/4")	WOOL	ULTRAFAB
40	-	-	-	-	-

**SEALANTS:**

FRAME AND PANEL CORNERS AND INSTALLATION SCREWS AT SILL AND JAMBS SEALED WITH JOINT SEALANT.

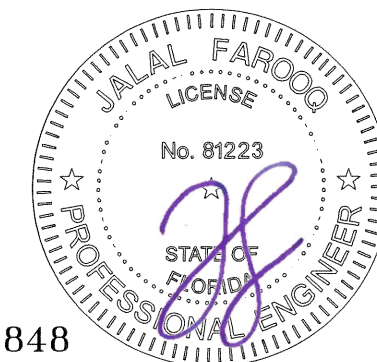

FL #21848

**af c**  
**AL-FAROOQ CORPORATION**  
 ENGINEERS & PRODUCT DEVELOPMENT  
 9360 SUNSET DRIVE, SUITE 220 (C.A.N. 3538)  
 MIAMI, FLORIDA 33173  
 TEL. (305) 264-8100 FAX. (305) 262-6978  
 COMP-ANL \ W12-31TMW

SERIES-390 ALUM. SLIDING GLASS DOOR (L.M.I.)  
**Assura Windows & Doors, LLC.**  
 1543 N. Powerline Road  
 Pompano Beach, Fl. 33069  
 Tel. (305) 887-2646 Fax. (-)

revisions:	no	date	description

date: 06-15-12  
 scale: 3/8" = 1"  
 dr. by: TARIQ  
 chk. by:

drawing no.  
**W12-31**  
 sheet 11 of 13

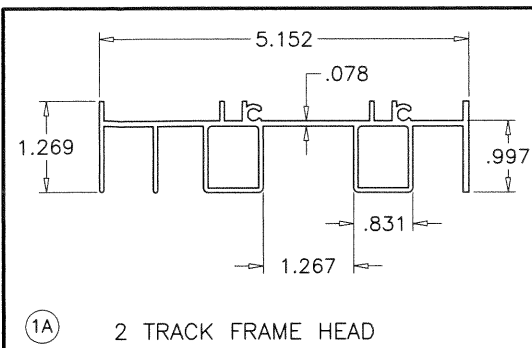

1A 2 TRACK FRAME HEAD

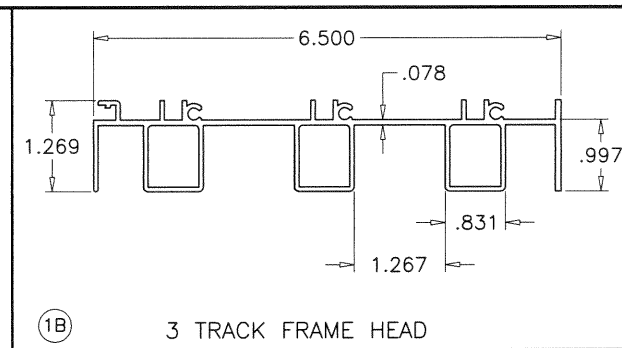

1B 3 TRACK FRAME HEAD

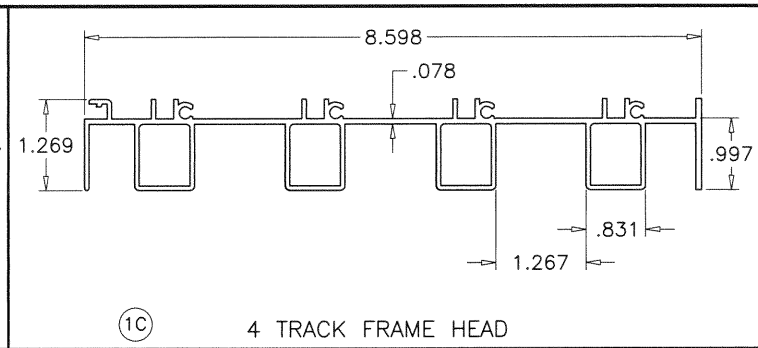

1C 4 TRACK FRAME HEAD

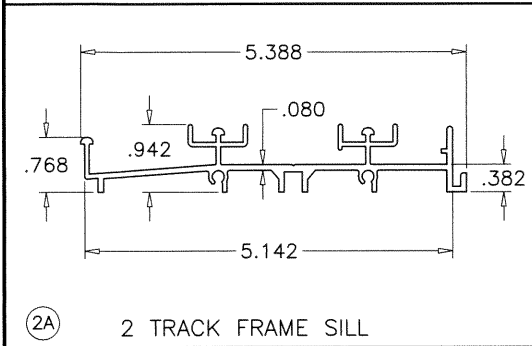

2A 2 TRACK FRAME SILL

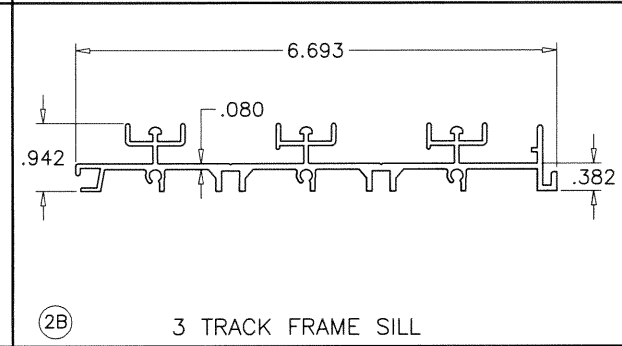

2B 3 TRACK FRAME SILL

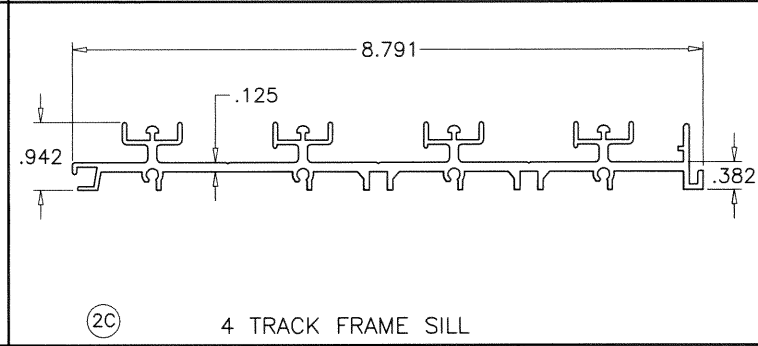

2C 4 TRACK FRAME SILL

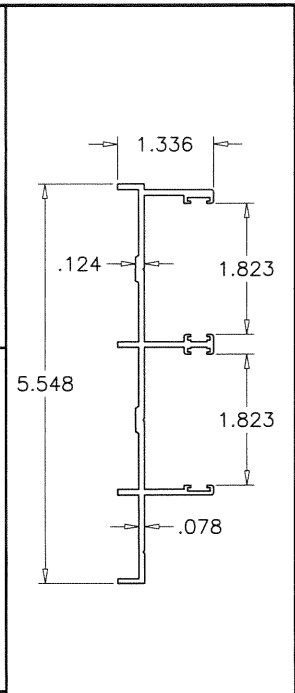

3A 2 TRACK FRAME JAMB

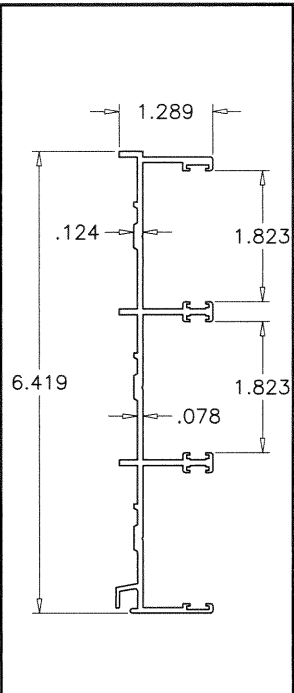

3B 3 TRACK FRAME JAMB

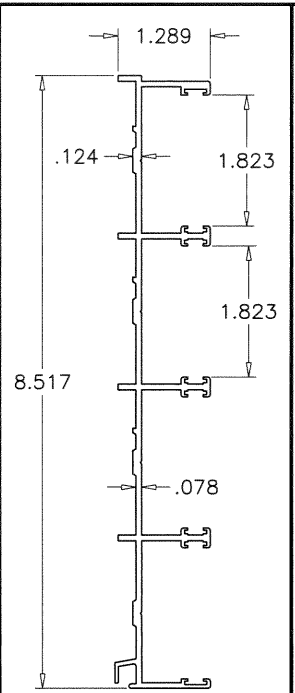

3C 4 TRACK FRAME JAMB

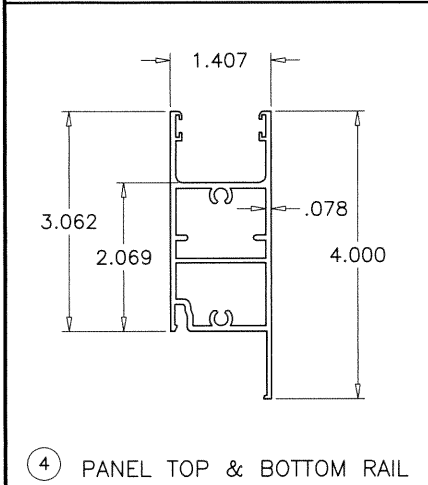

4 PANEL TOP & BOTTOM RAIL

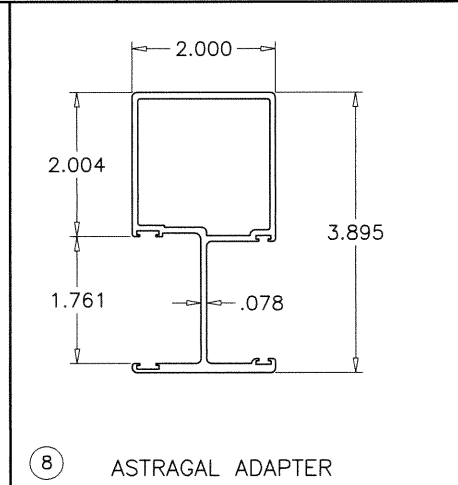

8 ASTRAGAL ADAPTER

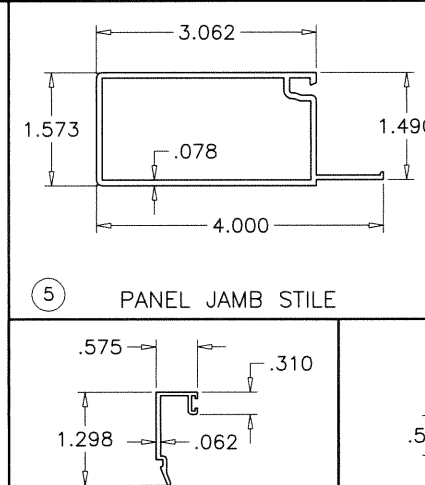

5 PANEL JAMB STILE

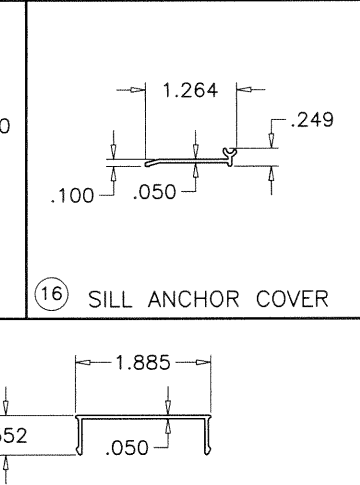

16 SILL ANCHOR COVER

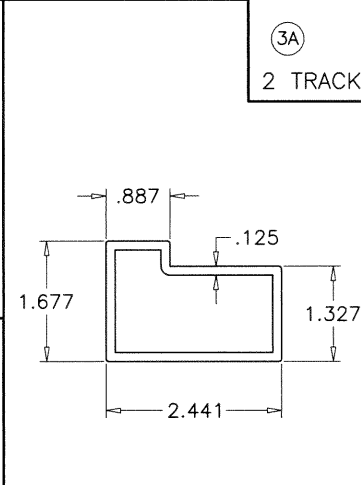

24 HOLLOW STIFFENER

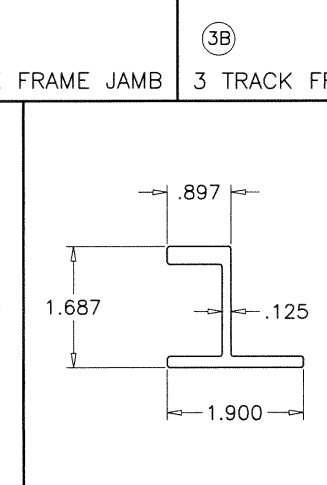

25 SOLID STIFFENER

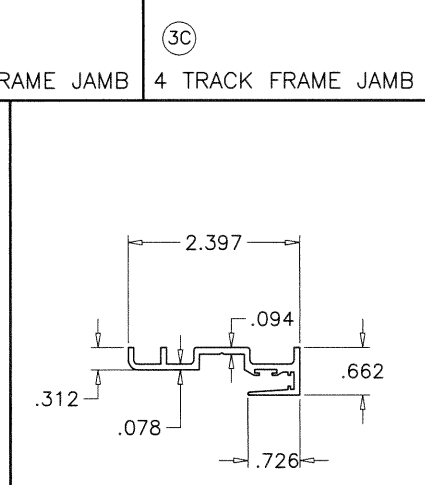

POCKET DOOR HOOK (TRIMMED)

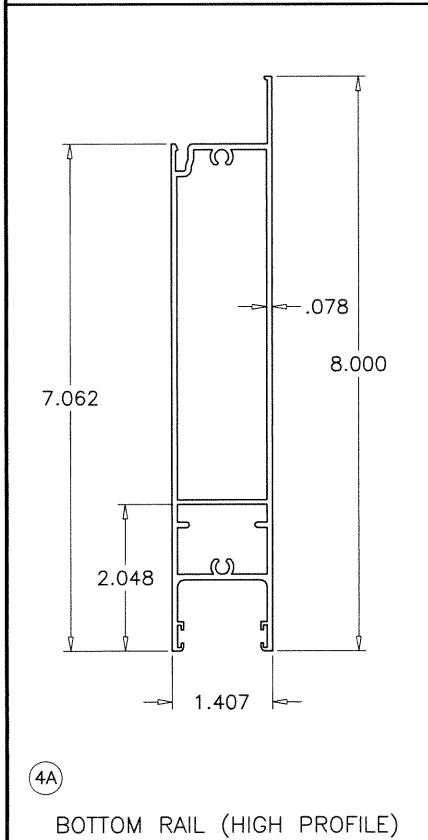

4A BOTTOM RAIL (HIGH PROFILE)

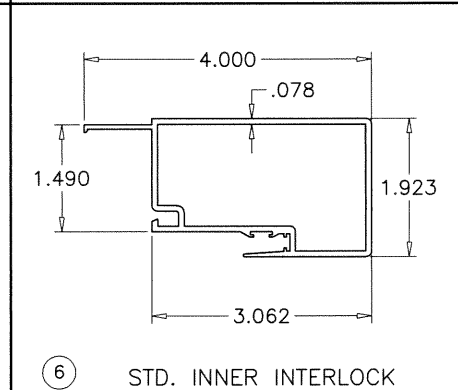

6 STD. INNER INTERLOCK

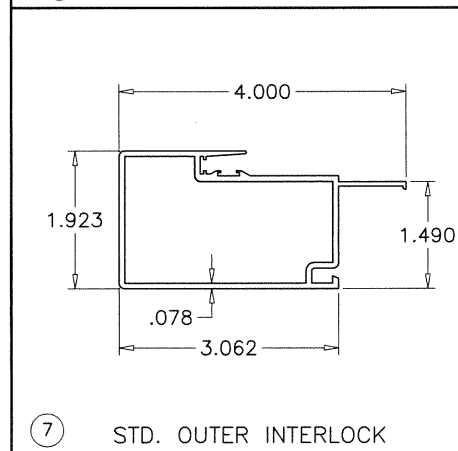

7 STD. OUTER INTERLOCK

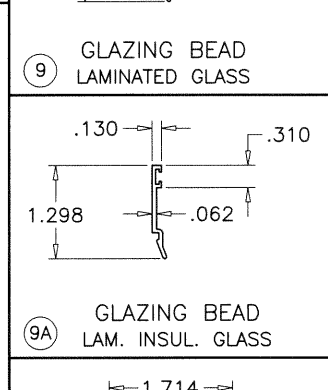

9 GLAZING BEAD LAMINATED GLASS

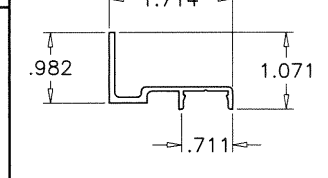

9A GLAZING BEAD LAM. INSUL. GLASS

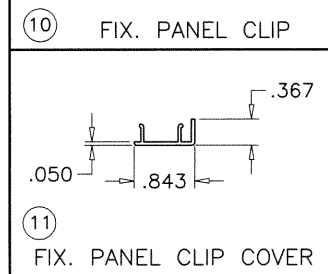

10 FIX. PANEL CLIP

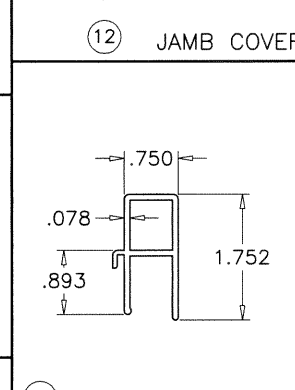

12 JAMB COVER

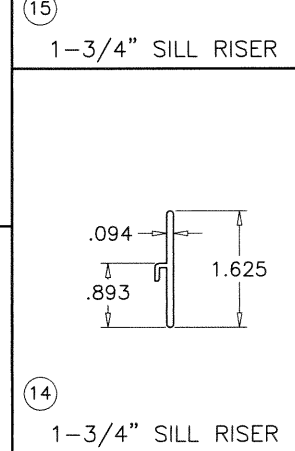

15 1-3/4" SILL RISER

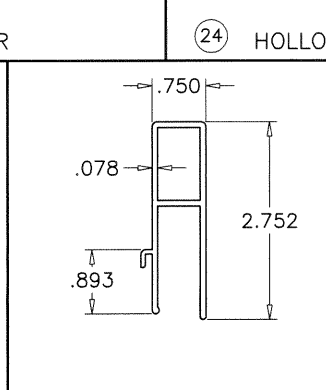

15A 2-3/4" SILL RISER

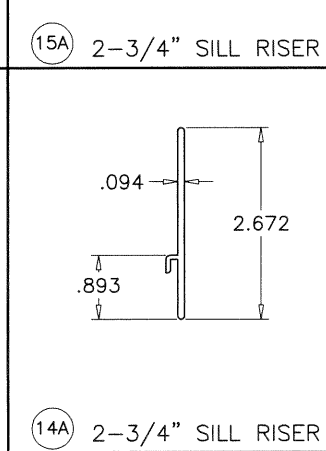

14A 2-3/4" SILL RISER

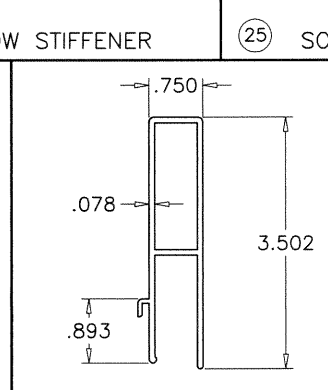

15B 3-1/2" SILL RISER

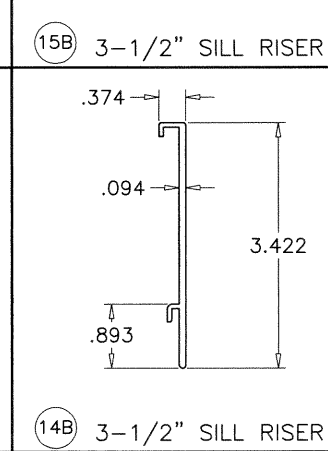

14B 3-1/2" SILL RISER

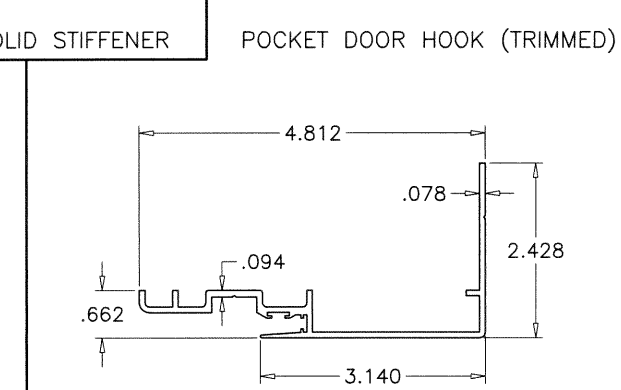

13 POCKET DOOR HOOK

**af c**  
**AL-FAROOQ CORPORATION**  
 ENGINEERS & PRODUCT DEVELOPMENT  
 9360 SUNSET DRIVE, SUITE 220 (C.A.N. 3538)  
 MIAMI, FLORIDA 33173 TEL. (305) 264-8100 FAX. (305) 262-6978  
 COMP-ANL\W12-31TMW

SERIES-390 ALUM. SLIDING GLASS DOOR (L.M.I.)  
**Assura Windows & Doors, LLC.**  
 1543 N. Powerline Road  
 Pompano Beach, Fl. 33069  
 Tel. (305) 887-2646 Fax. (-)

no	date	by	description

date: 06-15-12  
 scale: 3/8" = 1"  
 dr. by: TARIQ  
 chk. by:  
 drawing no.  
**W12-31**  
 sheet 12 of 13



10/15/2020  
 FL #21848

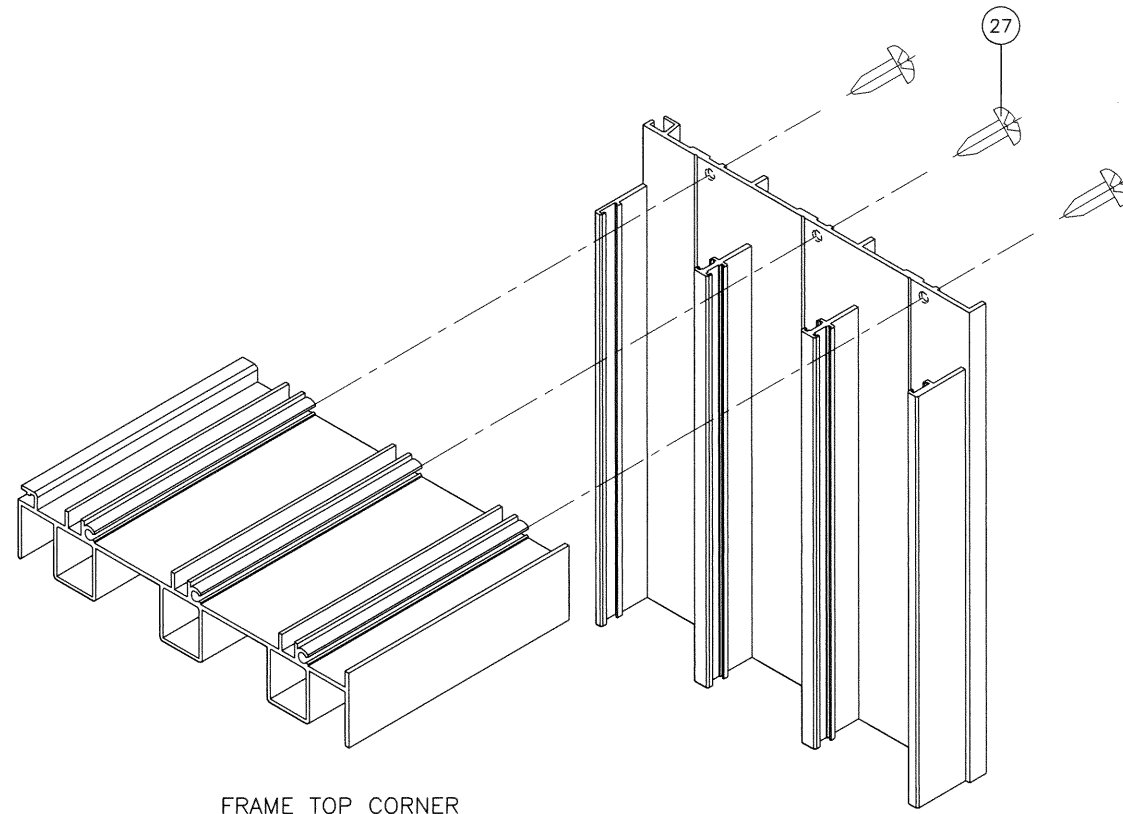

FRAME TOP CORNER

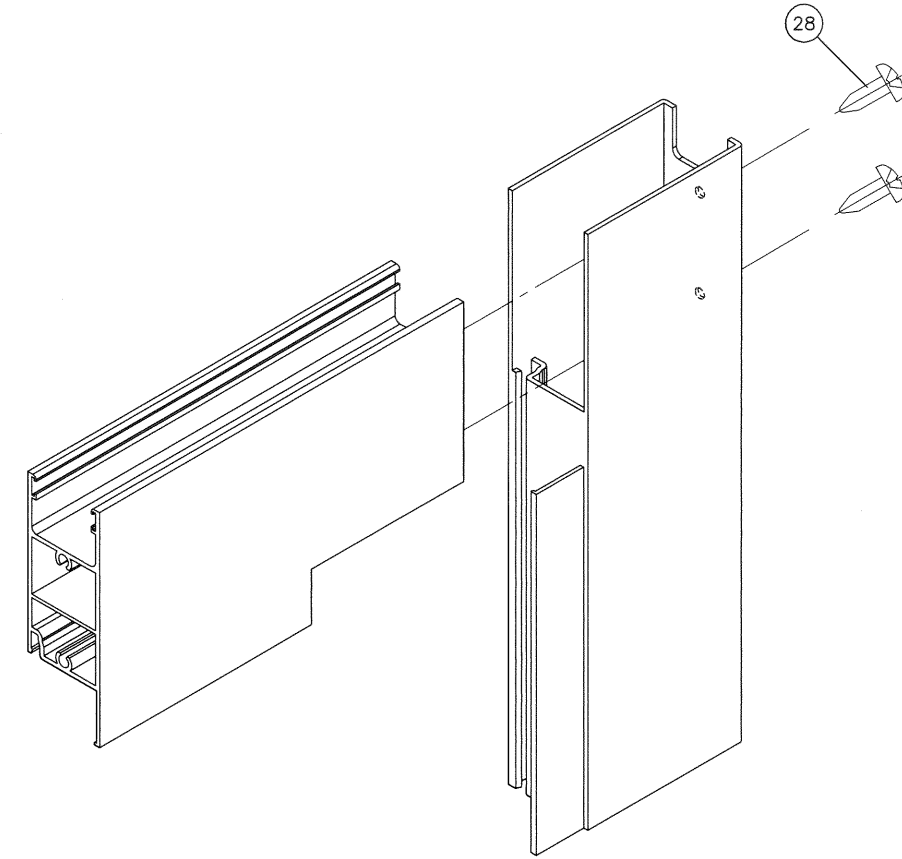

PANEL TOP/BOTTOM CORNER

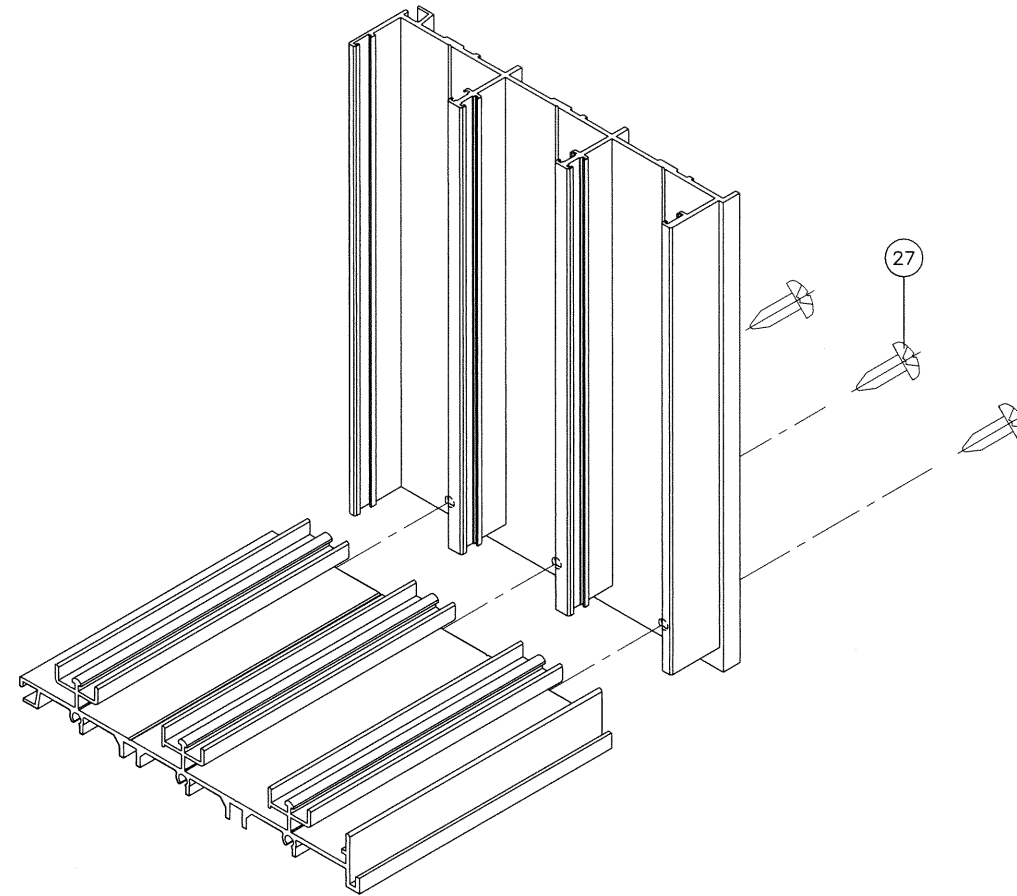

FRAME BOTTOM CORNER

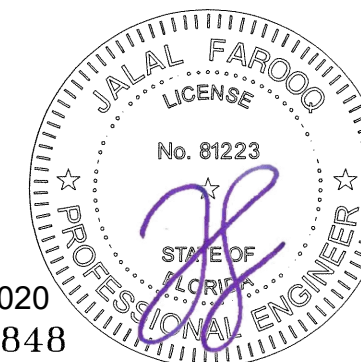

10/15/2020  
FL #21848

**afc**  
**AL-FAROOQ CORPORATION**  
ENGINEERS & PRODUCT DEVELOPMENT  
9360 SUNSET DRIVE, SUITE 220 (C.A.N. 3538)  
MIAMI, FLORIDA 33173  
TEL. (305) 264-8100 FAX. (305) 262-6978  
COMP-ANL \ W12-31T MW

SERIES-390 ALUM. SLIDING GLASS DOOR (L.M.I.)  
**Assura Windows & Doors, LLC.**  
1543 N. Powerline Road  
Pompano Beach, FL. 33069  
Tel. (305) 887-2646 Fax. (-)

no	date	by	description

date: 06-15-12  
scale: 3/8" = 1"  
dr. by: TARIQ  
chk. by:

drawing no.  
**W12-31**  
sheet 13 of 13