

THESE WINDOWS ARE RATED FOR LARGE & SMALL MISSILE IMPACT. SHUTTERS ARE NOT REQUIRED.

SERIES 2500 ALUMINUM SINGLE HUNG WINDOW

DESIGN LOAD RATINGS FOR THESE WINDOWS TO BE AS PER CHART SHOWN ON SHEETS 2 & 2.1.

APPROVAL APPLIES TO SINGLE UNITS OR SIDE BY SIDE COMBINATIONS OF S.H./S.H. OR SINGLE HUNG WITH OTHER F.B.C. APPR'D WINDOWS USING F.B.C. APPROVED MULLIONS IN BETWEEN.

LOWER DESIGN PRESSURE FROM WINDOWS OR MULLION APPROVAL WILL APPLY TO ENTIRE SYSTEM.

THIS PRODUCT HAS BEEN DESIGNED AND TESTED TO COMPLY WITH THE REQUIREMENTS OF THE 2017 (6TH EDITION)/2020 (7TH EDITION) FLORIDA BUILDING CODE INCLUDING HIGH VELOCITY HURRICANE ZONE (HVHZ).

1BY OR 2BY WOOD BUCKS & BUCK FASTENERS BY OTHERS, MUST BE DESIGNED AND INSTALLED ADEQUATELY TO TRANSFER APPLIED PRODUCT LOADS TO THE BUILDING STRUCTURE.

ANCHORS SHALL BE CORROSION RESISTANT, SPACED AS SHOWN ON DETAILS AND INSTALLED PER MANUF'S INSTRUCTIONS. SPECIFIED EMBEDMENT TO BASE MATERIAL SHALL BE BEYOND WALL DRESSING OR STUCCO.

A LOAD DURATION INCREASE IS USED IN DESIGN OF ANCHORS INTO WOOD ONLY.

ALL SHIMS TO BE HIGH IMPACT, NON-METALLIC AND NON-COMPRESSIBLE.

MATERIALS INCLUDING BUT NOT LIMITED TO STEEL/METAL SCREWS, THAT COME INTO CONTACT WITH OTHER DISSIMILAR MATERIALS SHALL MEET THE REQUIREMENTS OF THE 2017/2020 FLORIDA BLDG. CODE & ADOPTED STANDARDS.

THIS PRODUCT APPROVAL IS GENERIC AND DOES NOT PROVIDE INFORMATION FOR A SITE SPECIFIC PROJECT, i.e. LIFE SAFETY OF THIS PRODUCT, ADEQUACY OF STRUCTURE RECEIVING THIS PRODUCT AND SEALING AROUND OPENING FOR WATER INFILTRATION RESISTANCE ETC. CONDITIONS NOT SHOWN IN THIS DRAWING ARE TO BE ANALYZED SEPARATELY, AND TO BE REVIEWED BY BUILDING OFFICIAL.

DESIGN LOADS SHOWN ARE BASED ON 'ALLOWABLE STRESS DESIGN (ASD)'.

MANUFACTURER'S LABEL SHALL BE LOCATED ON A READILY VISIBLE LOCATION IN ACCORDANCE WITH SECTION 1709.9.3 OF FLORIDA BUILDING CODE. LABELING TO COMPLY WITH SECTION 1709.9.2.

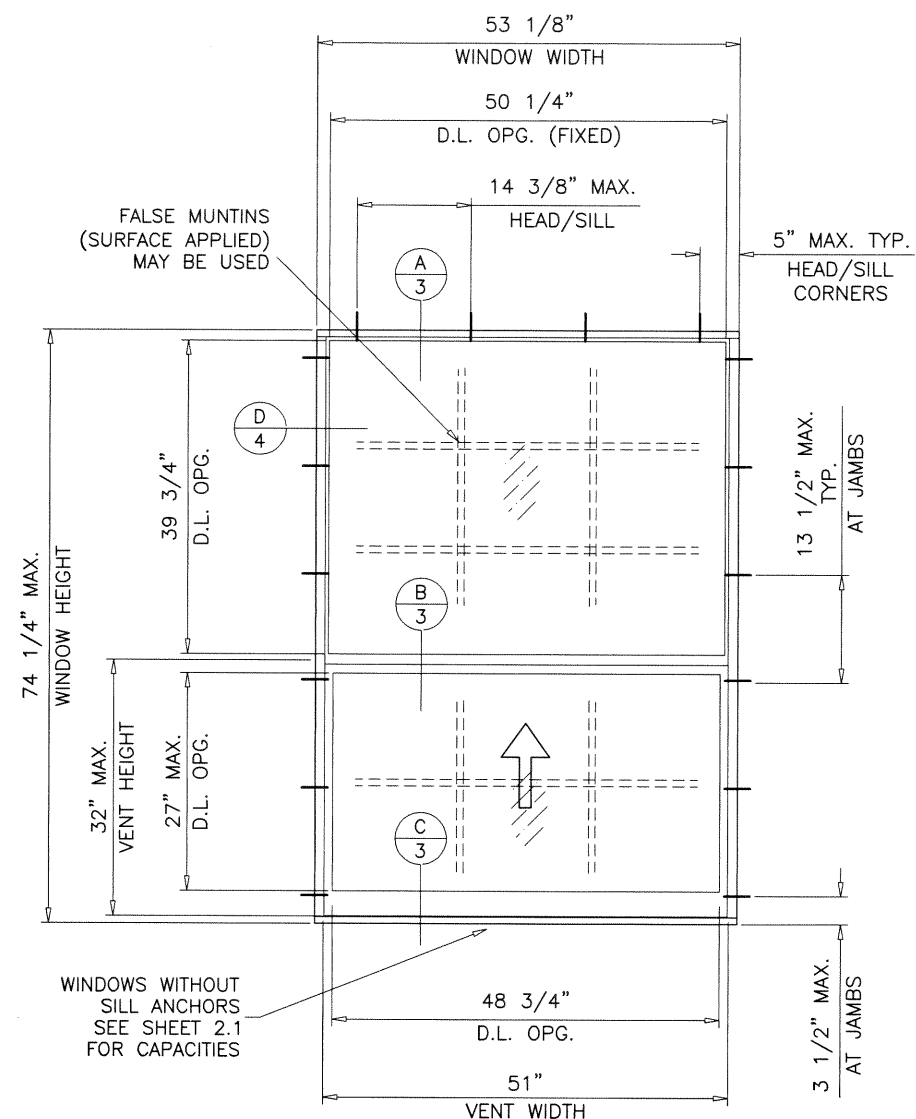
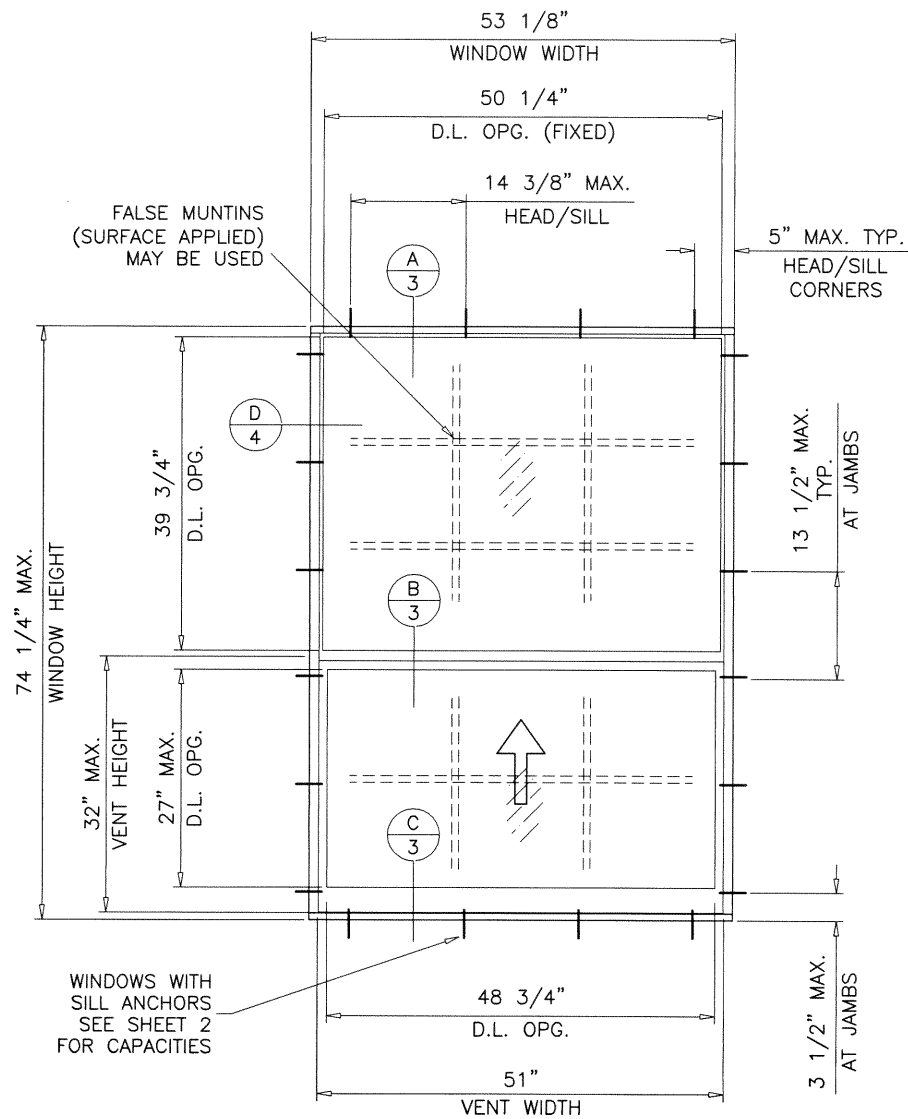

TYPICAL ELEVATION
TESTED UNITS

LAMINATED GLASS
LARGE MISSILE IMPACT

Sealed: 10/13/2020

FL #21857

- A- CONTRACTOR TO BE RESPONSIBLE FOR THE SELECTION, PURCHASE AND INSTALLATION OF THIS PRODUCT BASED ON THIS PRODUCT EVALUATION PROVIDED HE/SHE DOES NOT DEVIATE FROM THE CONDITIONS DETAILED ON THIS DOCUMENT.
- B- THIS PRODUCT EVALUATION DOCUMENT WILL BE CONSIDERED INVALID IF ALTERED BY ANY MEANS.
- C- SITE SPECIFIC PROJECTS SHALL BE PREPARED BY A FLORIDA REGISTERED ENGINEER OR ARCHITECT WHICH WILL BECOME THE ENGINEER OF RECORD (E.O.R.) FOR THE PROJECT AND WHO WILL BE RESPONSIBLE FOR THE PROPER USE OF THE P.E.D. ENGINEER OF RECORD, ACTING AS A DELEGATED ENGINEER TO THE P.E.D. ENGINEER SHALL SUBMIT TO THIS LATTER THE SITE SPECIFIC DRAWINGS FOR REVIEW.
- D- THIS P.E.D. SHALL BEAR THE DATE AND ORIGINAL SEAL AND SIGNATURE OF THE PROFESSIONAL ENGINEER OF RECORD THAT PREPARED IT.

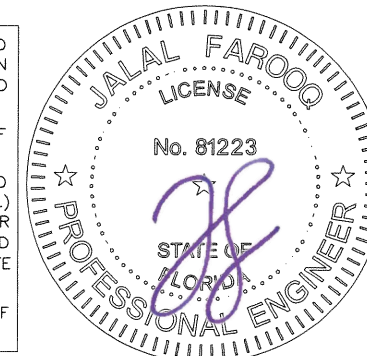

afc
AL-FAROOQ CORPORATION
ENGINEERS & PRODUCT DEVELOPMENT
9360 SUNSET DRIVE, SUITE 220 (C.A.N. 3538)
MIAMI, FLORIDA 33173
TEL. (305) 264-8100 FAX. (305) 262-6978
COMP-ANL \ W15-60AWP

SERIES 2500 ALUM SINGLE HUNG WINDOW (L.M.I.)
Assura Windows & Doors, LLC
d/b/a AWP Windows & Doors
1543 N. Powerline Road
Pompano Beach, FL 33069
Tel. (305) 887-2646 Fax. (-)

no	date	description	by
A	02.07.17	MANUF. NAME REV.	
B	10.05.17	UPDATED TO 2017 FBC	
C	12.07.17	NEW GLASS TYPE ADDED	
D	07.18.18	UPDATED TO 2017 FBC	
E	09.23.20	UPDATED TO 2020 FBC	

date: 08-22-15
scale: 1/2" = 1"
dr. by: TARIQ
chk. by:

drawing no.
W15-60
sheet 1 of 5

EQUAL LITES WINDOWS DESIGN LOAD CAPACITY - PSF WINDOWS WITH SILL ANCHORS				
WINDOW DIMS.		GLASS TYPES 'A', 'B' & 'D'		
WIDTH	HEIGHT	EXT.(+)	1NT.(-)	
19-1/8"	26"	70.0	90.0	
26-1/2"		70.0	90.0	
37"		(3)	70.0	90.0
42"		70.0	90.0	
48"		70.0	90.0	
53-1/8"	38-3/8"	70.0	90.0	
19-1/8"		70.0	90.0	
26-1/2"		70.0	90.0	
37"		(4)	70.0	90.0
42"		70.0	90.0	
48"	70.0	90.0		
53-1/8"	50-5/8"	70.0	90.0	
19-1/8"		70.0	90.0	
26-1/2"		70.0	90.0	
37"		(4)	70.0	90.0
42"		70.0	90.0	
48"	70.0	90.0		
53-1/8"	59"	60.0	65.0	
19-1/8"		70.0	90.0	
26-1/2"		70.0	90.0	
37"		(5)	70.0	90.0
42"		60.0	65.0	
48"	60.0	65.0		
53-1/8"	63"	60.0	65.0	
19-1/8"		70.0	90.0	
26-1/2"		70.0	90.0	
37"		(6)	60.0	65.0
42"		60.0	65.0	
48"	60.0	65.0		
53-1/8"	74-1/4"	60.0	65.0	
19-1/8"		70.0	90.0	
26-1/2"		70.0	90.0	
37"		(6)	60.0	65.0
42"		60.0	65.0	
48"	60.0	65.0		
53-1/8"	76"	60.0	65.0	
19-1/8"		70.0	90.0	
26-1/2"		70.0	90.0	
37"		(6)	60.0	65.0
42"		60.0	65.0	
48"	60.0	65.0		
51"	76"	60.0	65.0	
53-1/8"		60.0	65.0	

* NO. IN PARENTHESIS INDICATE NO. OF ANCHORS PER JAMB.

NOTE:
GLASS CAPACITIES ON THIS SHEET ARE
BASED ON ASTM E1300-09 (3 SEC. GUSTS)
AND FLORIDA BUILDING COMMISSION
DECLARATORY STATEMENT DCA05-DEC-219

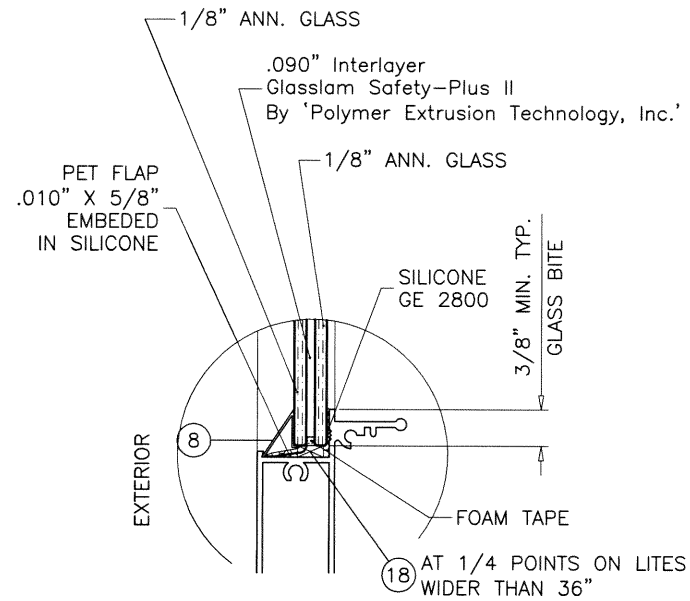
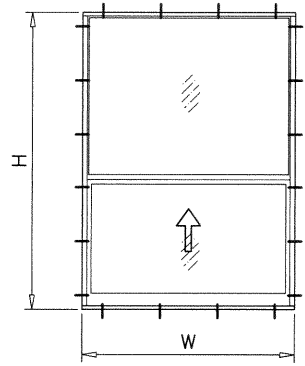

GLASS TYPE 'A'

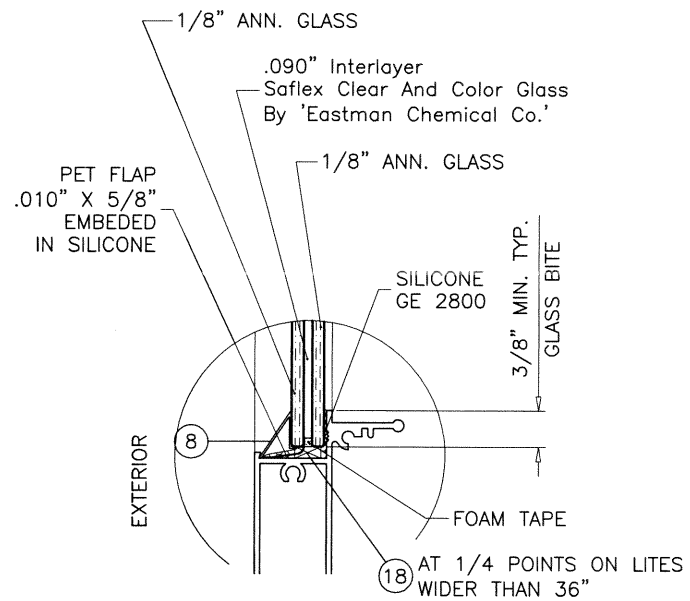

GLASS TYPE 'B'

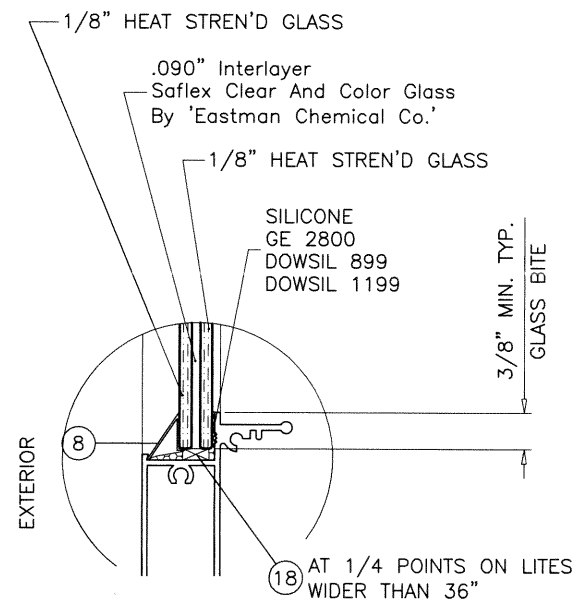

GLASS TYPE 'D'

GLAZING OPTIONS

UNEQUAL LITES (ORIEL TYPES) WINDOWS DESIGN LOAD CAPACITY - PSF WINDOWS WITH SILL ANCHORS				
WINDOW DIMS.		GLASS TYPES 'A', 'B' & 'D'		
WIDTH	HEIGHT	EXT.(+)	1NT.(-)	
19-1/8"	50-5/8"	70.0	90.0	
26-1/2"		70.0	90.0	
37"		70.0	90.0	
42"		(4)	60.0	65.0
48"		60.0	65.0	
53-1/8"	59"	60.0	65.0	
19-1/8"		70.0	90.0	
26-1/2"		70.0	90.0	
37"		(5)	60.0	65.0
42"		60.0	65.0	
48"	60.0	65.0		
53-1/8"	63"	60.0	65.0	
19-1/8"		70.0	90.0	
26-1/2"		70.0	90.0	
37"		(6)	60.0	65.0
42"		60.0	65.0	
48"	60.0	65.0		
51"	63"	60.0	65.0	
53-1/8"		60.0	65.0	
19-1/8"	74-1/4"	70.0	90.0	
26-1/2"		60.0	65.0	
37"		(6)	60.0	65.0
42"		60.0	65.0	
48"		60.0	65.0	
53-1/8"	76"	60.0	65.0	
19-1/8"		70.0	90.0	
26-1/2"		60.0	65.0	
37"		(6)	60.0	65.0
42"		60.0	65.0	

* NO. IN PARENTHESIS INDICATE NO. OF ANCHORS PER JAMB.

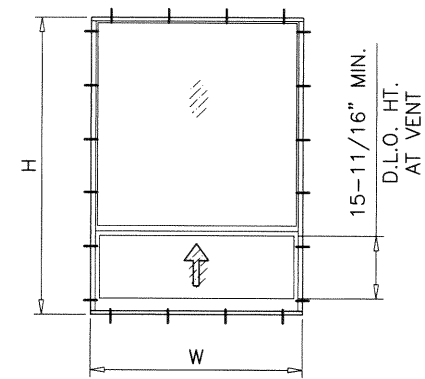

WINDOWS WITH SILL ANCHORS

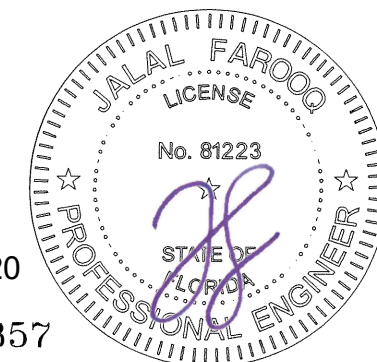

Sealed: 10/13/2020

FL #21857

af c
AL-FAROOQ CORPORATION
ENGINEERS & PRODUCT DEVELOPMENT
9360 SUNSET DRIVE, SUITE 220
MIAMI, FLORIDA 33173 (C.A.N. 3538)
TEL. (305) 264-8100 FAX. (305) 262-6978
COMP-ANL W15-60AWP

SERIES 2500 ALUM SINGLE HUNG WINDOW (L.M.I.)
Assura Windows & Doors, LLC
d/b/a AWP Windows & Doors
1543 N. Powerline Road
Pompano Beach, FL 33069
Tel. (305) 887-2646 Fax. (-)

no	date	by	description

date: 08-22-15
scale: 1/2" = 1"
dr. by: TARIQ
chk. by:

drawing no.
W15-60
sheet 2 of 5

EQUAL LITES WINDOWS DESIGN LOAD CAPACITY - PSF WINDOWS WITHOUT SILL ANCHORS						
WINDOW DIMS.		GLASS TYPE 'C'		GLASS TYPE 'D'		
WIDTH	HEIGHT	EXT.(+)	1NT.(-)	EXT.(+)	1NT.(-)	
19-1/8"	26"	60.0	65.0	70.0	90.0	
26-1/2"		60.0	65.0	70.0	90.0	
37"		60.0	65.0	70.0	90.0	
42"		(3)	60.0	65.0	70.0	90.0
48"		60.0	65.0	70.0	90.0	
53-1/8"		60.0	65.0	70.0	83.1	
19-1/8"	38-3/8"	60.0	65.0	70.0	90.0	
26-1/2"		60.0	65.0	70.0	90.0	
37"		60.0	65.0	70.0	90.0	
42"		(4)	60.0	65.0	70.0	90.0
48"		60.0	65.0	70.0	83.1	
53-1/8"		60.0	65.0	70.0	75.1	
19-1/8"	50-5/8"	60.0	65.0	70.0	90.0	
26-1/2"		60.0	65.0	70.0	90.0	
37"		60.0	65.0	70.0	81.7	
42"		(4)	60.0	65.0	70.0	72.0
48"		60.0	63.0	60.0	63.0	
53-1/8"		56.9	56.9	56.9	56.9	
19-1/8"	59"	60.0	65.0	70.0	90.0	
26-1/2"		60.0	65.0	70.0	90.0	
37"		60.0	65.0	70.0	87.7	
42"		(5)	60.0	65.0	60.0	65.0
48"		60.0	65.0	60.0	65.0	
53-1/8"		60.0	61.1	60.0	61.1	
19-1/8"	63"	60.0	65.0	70.0	90.0	
26-1/2"		60.0	65.0	70.0	90.0	
37"		60.0	65.0	70.0	90.0	
42"		(6)	60.0	65.0	60.0	65.0
48"		60.0	65.0	60.0	65.0	
53-1/8"		60.0	65.0	60.0	65.0	
19-1/8"	74-1/4"	60.0	65.0	70.0	90.0	
26-1/2"		60.0	65.0	70.0	90.0	
37"		60.0	65.0	60.0	65.0	
42"		(6)	60.0	65.0	60.0	65.0
48"		60.0	64.4	60.0	64.4	
53-1/8"		58.2	58.2	58.2	58.2	
19-1/8"	76"	60.0	65.0	70.0	90.0	
26-1/2"		60.0	65.0	70.0	90.0	
37"		60.0	65.0	60.0	65.0	
42"		(6)	60.0	65.0	60.0	65.0
48"		60.0	63.0	60.0	63.0	
51"		59.2	59.2	59.2	59.2	

* NO. IN PARENTHESIS INDICATE NO. OF ANCHORS PER JAMB.

NOTE:
GLASS CAPACITIES ON THIS SHEET ARE
BASED ON ASTM E1300-09 (3 SEC. GUSTS)
AND FLORIDA BUILDING COMMISSION
DECLARATORY STATEMENT DCA05-DEC-219

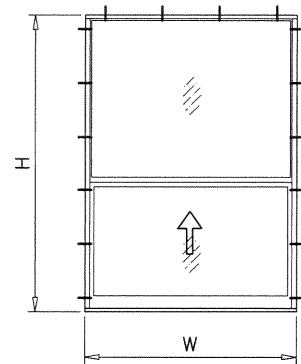

UNEQUAL LITES (ORIEL TYPES) WINDOWS DESIGN LOAD CAPACITY - PSF WINDOWS WITHOUT SILL ANCHORS						
WINDOW DIMS.		GLASS TYPE 'C'		GLASS TYPE 'D'		
WIDTH	HEIGHT	EXT.(+)	1NT.(-)	EXT.(+)	1NT.(-)	
19-1/8"	50-5/8"	60.0	65.0	70.0	90.0	
26-1/2"		60.0	65.0	70.0	90.0	
37"		60.0	65.0	70.0	81.7	
42"		(4)	60.0	65.0	60.0	65.0
48"		60.0	63.0	60.0	63.0	
53-1/8"		56.9	56.9	56.9	56.9	
19-1/8"	59"	60.0	65.0	70.0	90.0	
26-1/2"		60.0	65.0	70.0	90.0	
37"		60.0	65.0	60.0	65.0	
42"		(5)	60.0	65.0	60.0	65.0
48"		60.0	65.0	60.0	65.0	
53-1/8"		60.0	61.1	60.0	61.1	
19-1/8"	63"	60.0	65.0	70.0	90.0	
26-1/2"		60.0	65.0	70.0	90.0	
37"		60.0	65.0	60.0	65.0	
42"		(6)	60.0	65.0	60.0	65.0
48"		60.0	65.0	60.0	65.0	
51"		60.0	65.0	60.0	65.0	
19-1/8"	74-1/4"	60.0	65.0	70.0	90.0	
26-1/2"		(6)	60.0	65.0	60.0	65.0
37"		60.0	65.0	60.0	65.0	
19-1/8"	76"	60.0	65.0	70.0	90.0	
26-1/2"		(6)	60.0	65.0	60.0	65.0
37"		60.0	65.0	60.0	65.0	

* NO. IN PARENTHESIS INDICATE NO. OF ANCHORS PER JAMB.

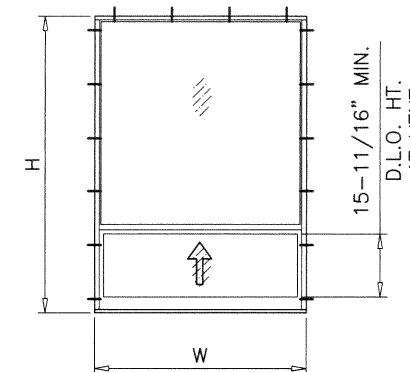

WINDOWS WITHOUT
SILL ANCHORS

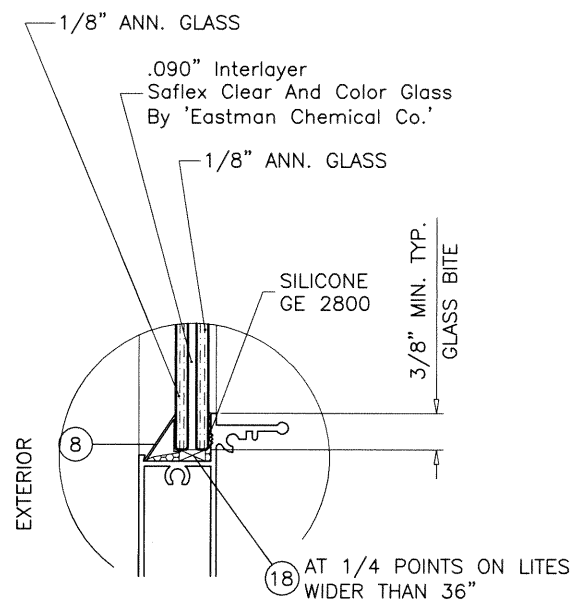

GLASS TYPE 'C'

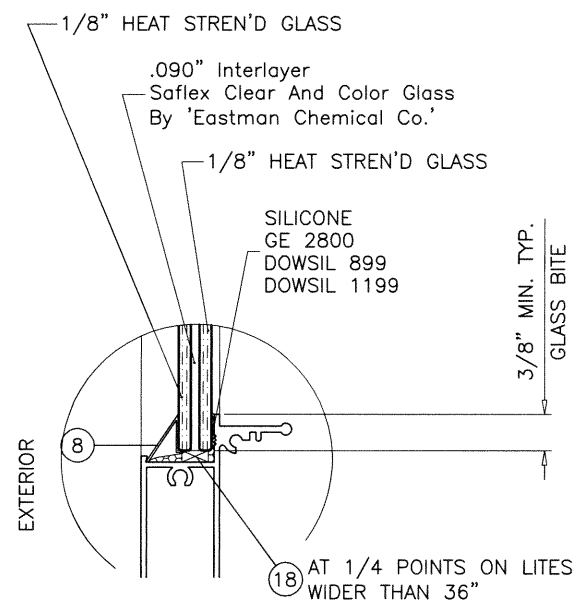

GLASS TYPE 'D'

GLAZING OPTIONS

Sealed: 10/13/2020

FL #21857

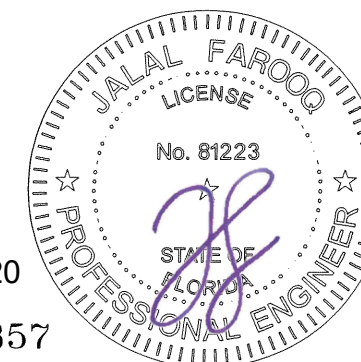

afC
AL-FAROOQ CORPORATION
ENGINEERS & PRODUCT DEVELOPMENT
9360 SUNSET DRIVE, SUITE 220 (C.A.N. 3538)
MIAMI, FLORIDA 33173 FAX. (305) 262-6978
TEL. (305) 264-8100

SERIES 2500 ALUM SINGLE HUNG WINDOW (L.M.I.)
Assura Windows & Doors, LLC
d/b/a AWP Windows & Doors
1543 N. Powerline Road
Pompano Beach, FL 33069
Tel. (305) 887-2646 Fax. (-)

no	date	description

date: 08-22-15	scale: 1/2" = 1"
dr. by: TARIQ	chk. by:

drawing no.
W15-60
sheet 2.1 of 5

COMP-ANL W15-60AWP

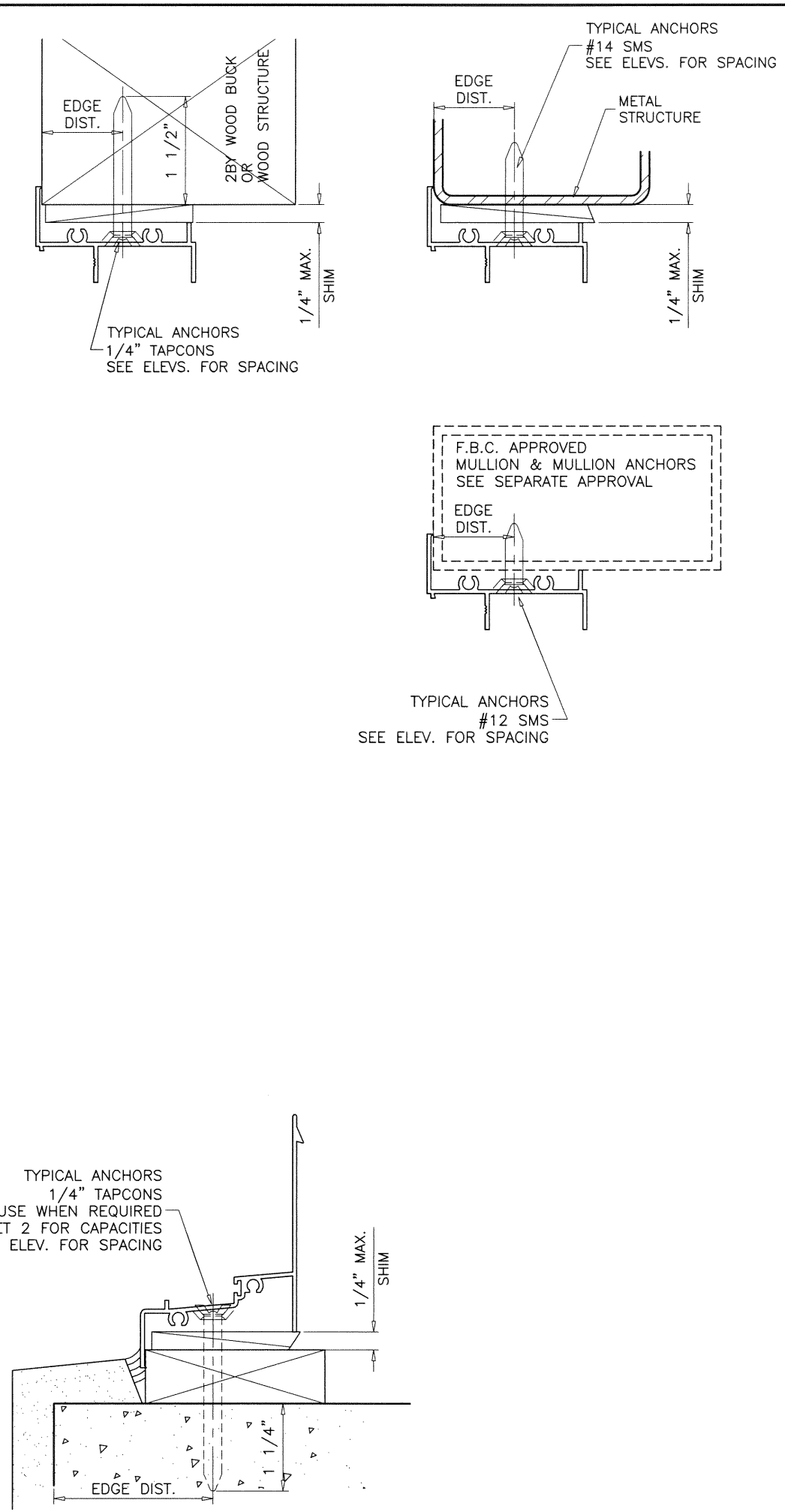
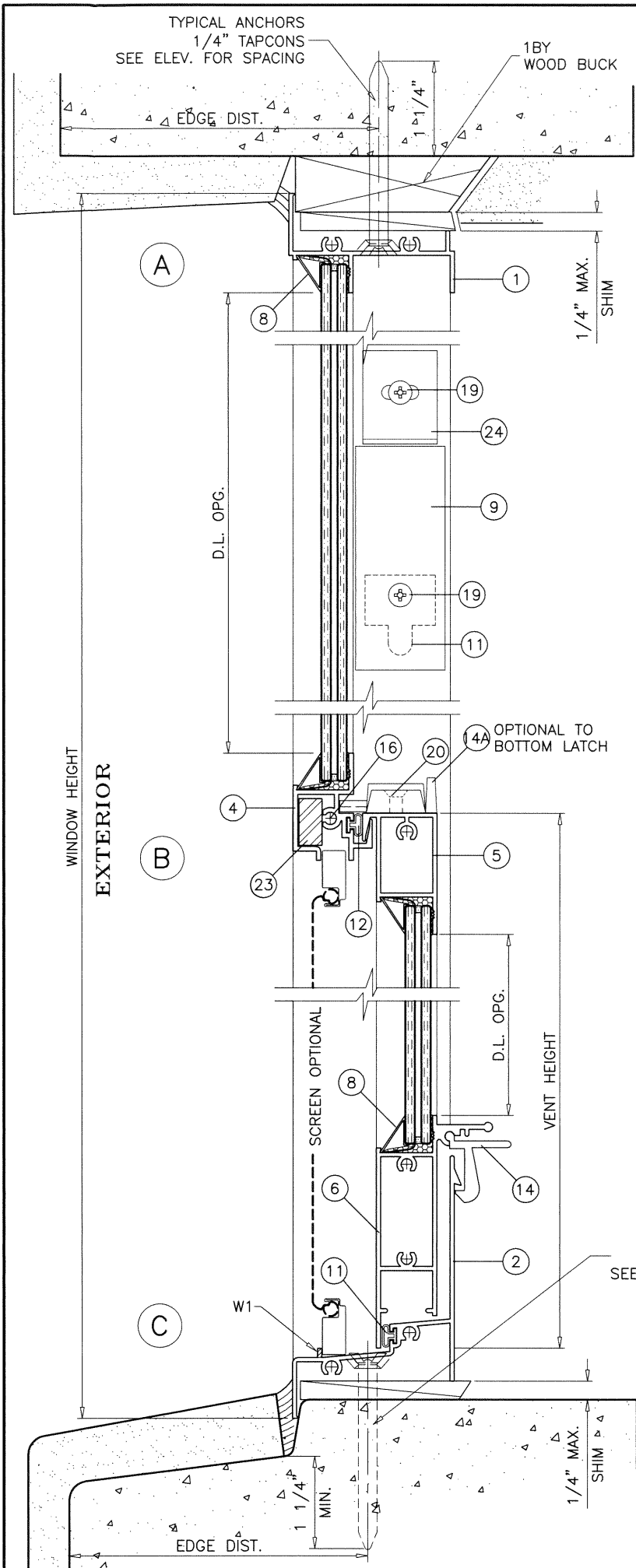

WOOD BUCKS AND METAL STRUCTURE NOT BY 'AWP WINDOWS' MUST SUSTAIN LOADS IMPOSED BY GLAZING SYSTEM AND TRANSFER THEM TO THE BUILDING STRUCTURE.

TYPICAL ANCHORS: SEE ELEV. FOR SPACING
1/4" DIA. TAPCON BY 'ITW' ($F_u=125$ KSI, $F_y=100$ KSI)
1/4" DIA. ULTRACON+ BY 'DEWALT' ($F_u=164$ KSI, $F_y=148$ KSI)
 INTO 2BY WOOD BUCKS OR WOOD STRUCTURES
 1-1/2" MIN. PENETRATION INTO WOOD (HEAD/SILL/JAMBS)
 THRU 1BY BUCKS INTO CONC. OR BLOCKS
 1-1/4" MIN. EMBED INTO CONCRETE (HEAD/SILL/JAMBS)
 1-1/4" MIN. EMBED INTO BLOCKS (JAMBS)
 DIRECTLY INTO CONCRETE OR BLOCKS
 1-1/4" MIN. EMBED INTO CONCRETE (HEAD/SILL/JAMBS)
 1-1/4" MIN. EMBED INTO BLOCKS (JAMBS)

#14 SMS OR SELF DRILLING SCREWS (GRADE 2 CRS)
 INTO METAL STRUCTURES (HEAD/SILL/JAMBS)
 (3) THREADS MIN. TO EXTEND BEYOND METAL THICKNESS
 ALUMINUM: 1/8" THK. MIN. (6063-T5 MIN.)
 STEEL: 1/8" THK. MIN. ($F_y = 36$ KSI MIN.)
 (STEEL IN CONTACT WITH ALUMINUM TO BE PLATED OR PAINTED)

#12 SMS OR SELF DRILLING SCREWS (GRADE 2 CRS)
 INTO F.B.C. APPROVED MULLIONS
 (3) THREADS MIN. TO EXTEND BEYOND METAL THICKNESS
 ALUMINUM: 1/8" THK. MIN. (6063-T5 MIN.) (NO SHIMS)
 STEEL: 1/8" THK. MIN. ($F_y = 36$ KSI MIN.) (NO SHIMS)
 (STEEL IN CONTACT WITH ALUMINUM TO BE PLATED OR PAINTED)

TYPICAL EDGE DISTANCE
 INTO CONCRETE AND BLOCKS = 2" MIN.
 INTO WOOD STRUCTURE = 1" MIN.
 INTO METAL STRUCTURE = 3/4" MIN.

WOOD AT HEAD, SILL OR JAMBS $SG = 0.55$ MIN.
 CONCRETE AT HEAD, SILL OR JAMBS $f'_c = 3000$ PSI MIN.
 C-90 HOLLOW/FILLED BLOCK AT JAMBS $f'_m = 2000$ PSI MIN.

SEALANTS:
 ALL JOINTS AND FRAME CONNECTIONS SEALED WITH SCHNEE MOREHEAD SEAM SEALER SM5555.

WEEPHOLES:
 W1 = 3/4" WEEP NOTCH AT EACH END



Sealed: 10/13/2020
 FL #21857

af c

AL-FAROOQ CORPORATION
 ENGINEERS & PRODUCT DEVELOPMENT
 9360 SUNSET DRIVE, SUITE 220 (C.A.N. 3538)
 MIAMI, FLORIDA 33173 TEL. (305) 262-6978 FAX. (305) 262-6978
 COMP-ANL\W15-60AWP

SERIES 2500 ALUM SINGLE HUNG WINDOW (L.M.I.)

Assura Windows & Doors, LLC
 d/b/a AWP Windows & Doors
 1543 N. Powerline Road
 Pompano Beach, FL 33069
 Tel. (305) 887-2646 Fax. (-)

no	date	by	description

date: 08-22-15
 scale: 1/2" = 1"
 dr. by: TARIQ
 chk. by:
 drawing no. W15-60
 sheet 3 of 5

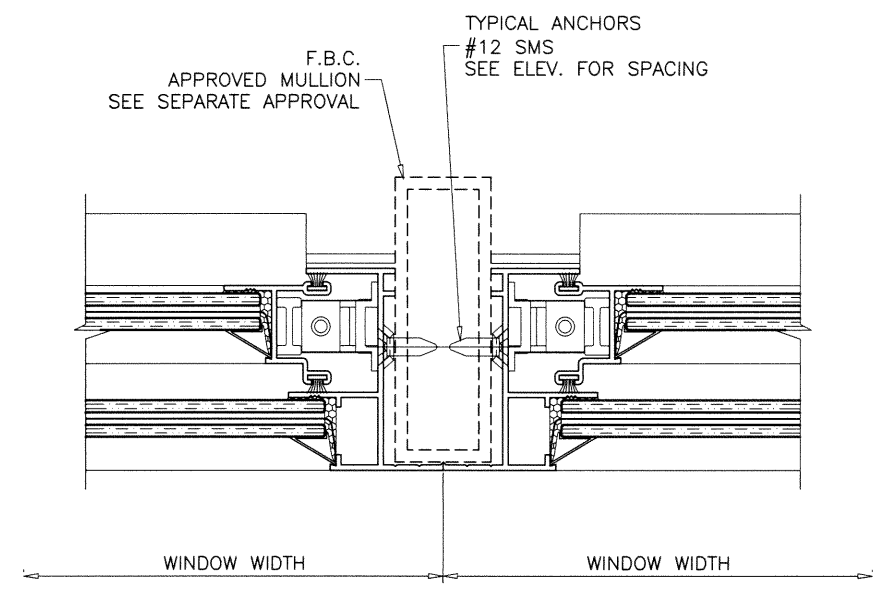

ITEM #	PART #	REQD.	DESCRIPTION	MATERIAL	MANF./SUPPLIER/REMARKS
1	YE-169	1	FRAME HEAD	6063-T6	-
2	YE-167	1	FRAME SILL	6063-T6	-
3	YE-102	2	FRAME JAMB	6063-T6	-
4	YE-152	1	FIXED RAIL	6063-T6	-
5	YE-151	1	VENT TOP RAIL	6063-T6	-
6	YE-168	1	VENT BOTTOM RAIL	6063-T6	-
7	YE-92	2	VENT JAMB	6063-T6	-
8	YB-4	AS REQD.	GLAZING BEAD	ALUMINUM	ROLL FORMED
9	YH-518	2/ VENT	SASH STOP	RIGID VINYL	-
10	-	2/ VENT	BLOCK & TACKLE BALANCE	-	-
11	YH-505	2/ VENT	BALANCE CLIP	ALUMINUM	-
12	YH-622	AS REQD.	BULB W'STRIPPING	VINYL	SINGLE ROW
13	YH-4004	AS REQD.	FIN SEAL W'STRIPPING .187 X .250	WOOL	ULTRAFAB
14	YH-504	2/ VENT	SPRING LOADED VENT LATCHES	NYLON/CELCON	AT 11" FROM ENDS
14A	YH-515	2/ VENT	SWEEP LOCKS	ZAMAK	AT 11" FROM ENDS
15	YF-1	8	FRAME ASSEMBLY SCREWS (#10 X 3/4")	CRS	PLATED, PH SMS
16	YF-10	2/ VENT	FIXED RAIL SCREWS (#8 X 1")	CRS	CAD PLATED, PH SMS
17	YF-12	6/ VENT	VENT ASSEMBLY SCREWS (#8 X 1-1/4")	CRS	CAD PLATED, PH SMS
18	-	AS REQD.	SETTING BLOCKS	EPDM	DUROMETER 80±5 SHORE A
19	YF-6	1/ CLIP	#10 X 1/4" PH SMS POINT B	-	-
20	YF-14	2/ LOCK	SWEEP LOCK SCREWS (#8 X 5/8")	-	OH SMS
21	YC-15SP	2/ VENT	SELF ADHESIVE PAD (.375" X .31" X .75")	FOAM	-
22	YH-519	2/ VENT	BALANCE CAM	PLASTIC	-
23	YH-519	1	REINFORCING BAR (.627 X .312")	STEEL	HRB93
24	-	2/ VENT	SASH STOP (1" X 1-1/4" X 1/16")	ALUMINUM	ON 74-1/4" HIGH ONLY

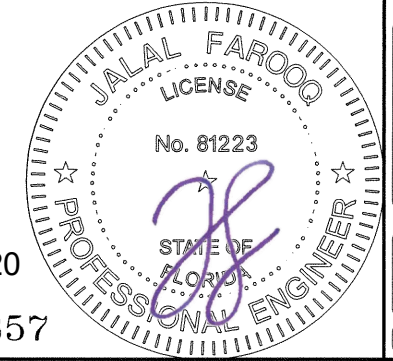
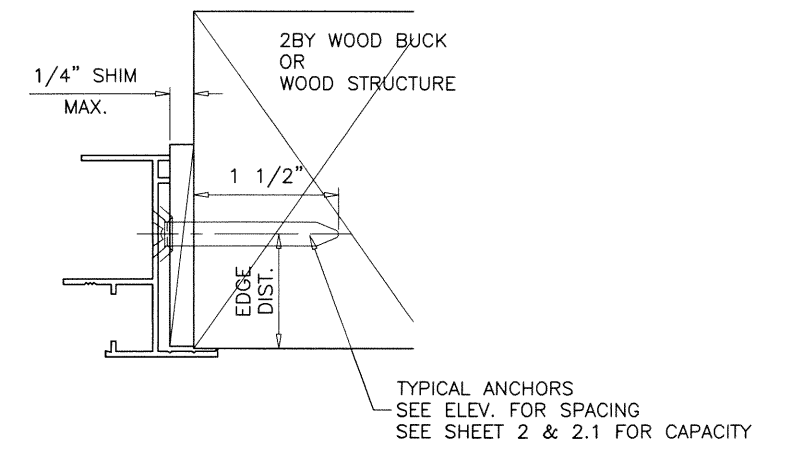
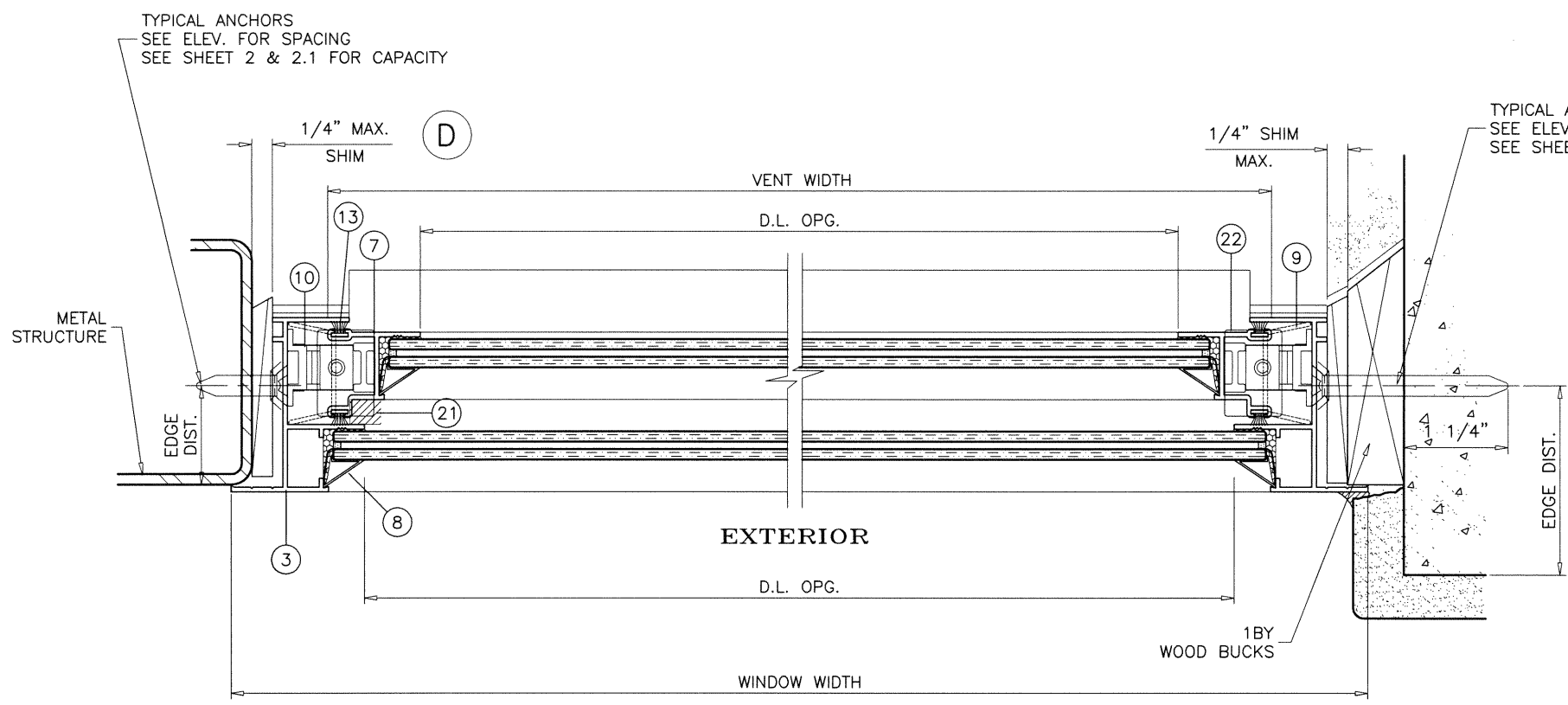

Sealed: 10/13/2020
FL #21857

af c
AL-FAROOQ CORPORATION
ENGINEERS & PRODUCT DEVELOPMENT
9360 SUNSET DRIVE, SUITE 220 (C.A.N. 3538)
MIAMI, FLORIDA 33173 FAX. (305) 262-6978
TEL. (305) 264-8100

SERIES 2500 ALUM SINGLE HUNG WINDOW (L.M.I.)
Assura Windows & Doors, LLC
d/b/a AWP Windows & Doors
1543 N. Powerline Road
Pompano Beach, FL 33069
Tel. (305) 887-2646 Fax. (-)

revisions:	
no	date by description

date: 08-22-15
scale: 1/2" = 1"
dr. by: TARIQ
chk. by:

drawing no.
W15-60

sheet 4 of 5

COMP-ANL\W15-60AWP

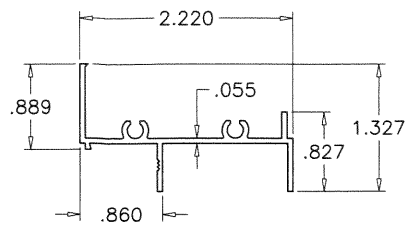

FRAME HEAD

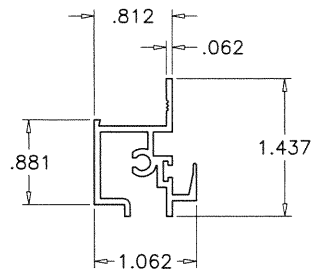

FIXED RAIL

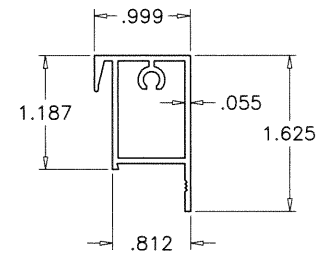

VENT TOP RAIL

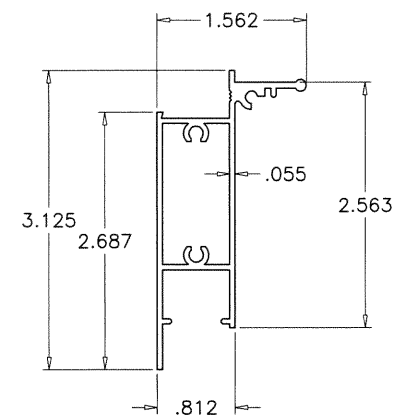

VENT BOTTOM RAIL

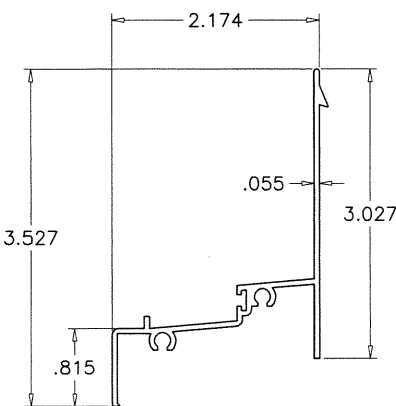

FRAME SILL

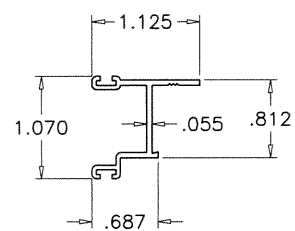

VENT SIDE RAIL

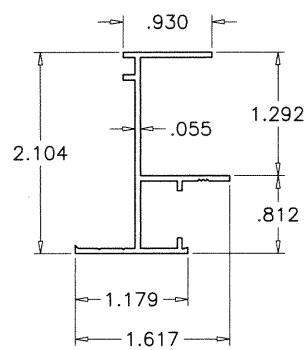

FRAME JAMB

3/4" WEEP NOTCH
AT EACH END OF
SCREEN RETAINING LEG

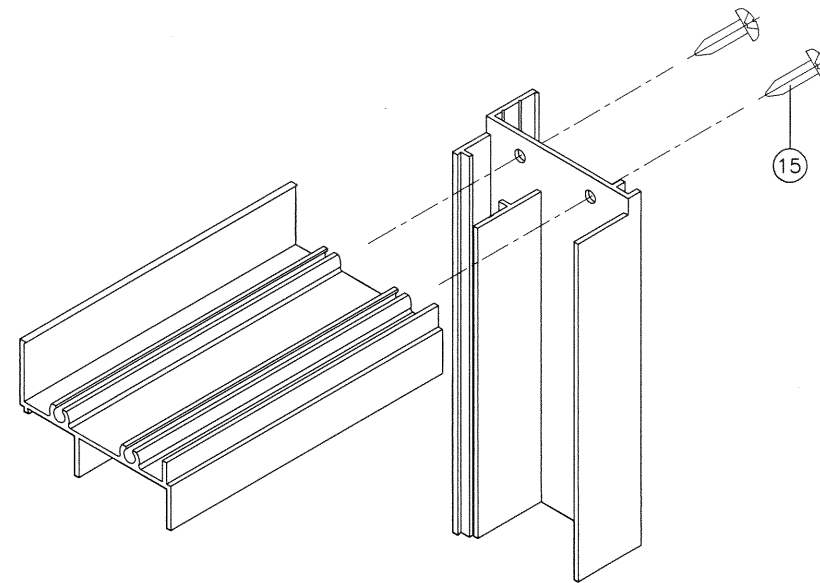

S.H. FRAME CORNER DETAIL

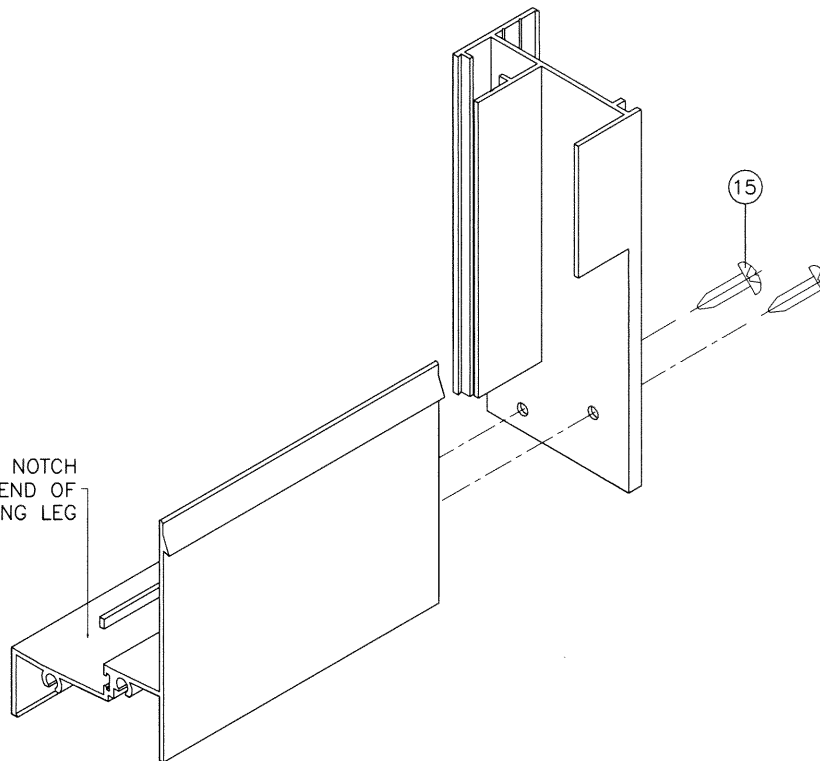

S.H. VENT CORNER DETAIL

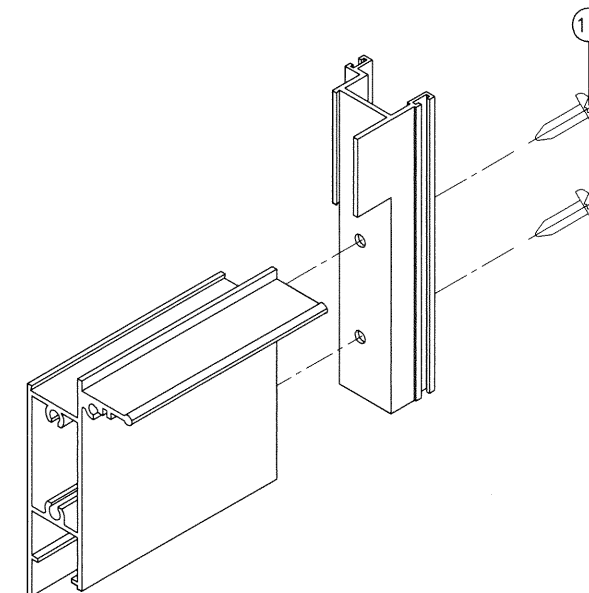
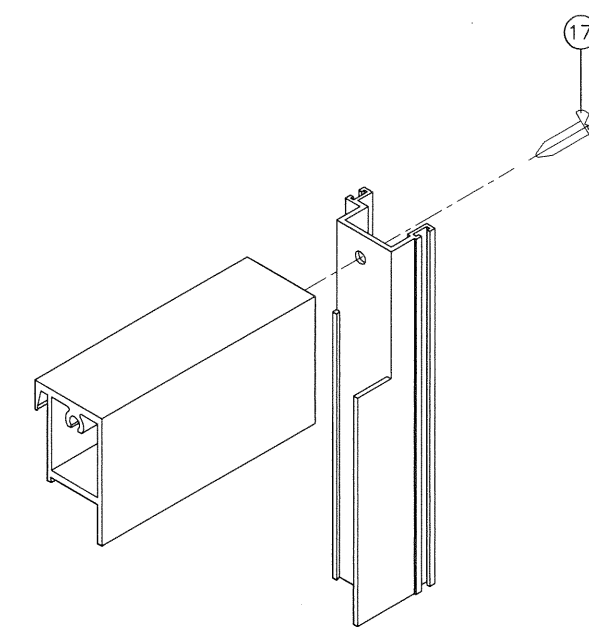

Sealed: 10/13/2020

FL #21857

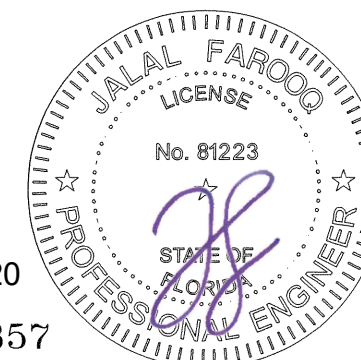

afc
AL-FAROOQ CORPORATION
 ENGINEERS & PRODUCT DEVELOPMENT
 9360 SUNSET DRIVE, SUITE 220 (C.A.N. 3538)
 MIAMI, FLORIDA 33173 TEL. (305) 262-6978 FAX. (305) 264-8100
 COMP-ANL\W15-60AWP

SERIES 2500 ALUM SINGLE HUNG WINDOW (L.M.I.)
 Assura Windows & Doors, LLC
 d/b/a AWP Windows & Doors
 1543 N. Powerline Road
 Pompano Beach, Fl. 33069
 Tel. (305) 887-2646 Fax. (-)

no	date	by	description

date: 08-22-15
 scale: 1/2" = 1"
 dr. by: TARIQ
 chk. by:

drawing no.
W15-60
 sheet 5 of 5