

GLASS TYPE 'A'
7/16" OVERALL LAM. GLASS

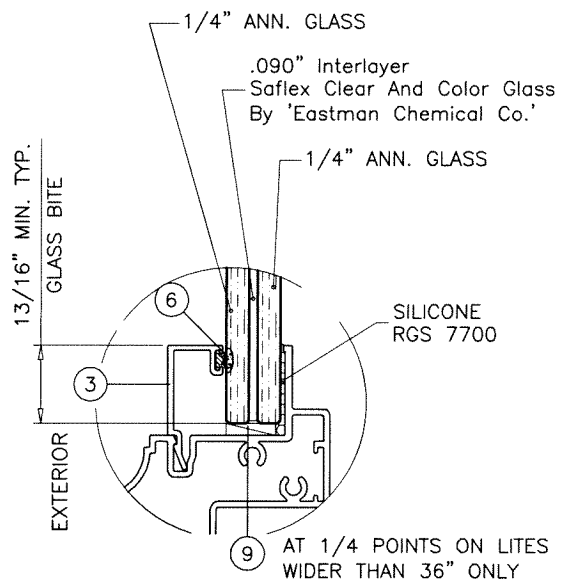

GLASS TYPE 'B'
9/16" OVERALL LAM. GLASS

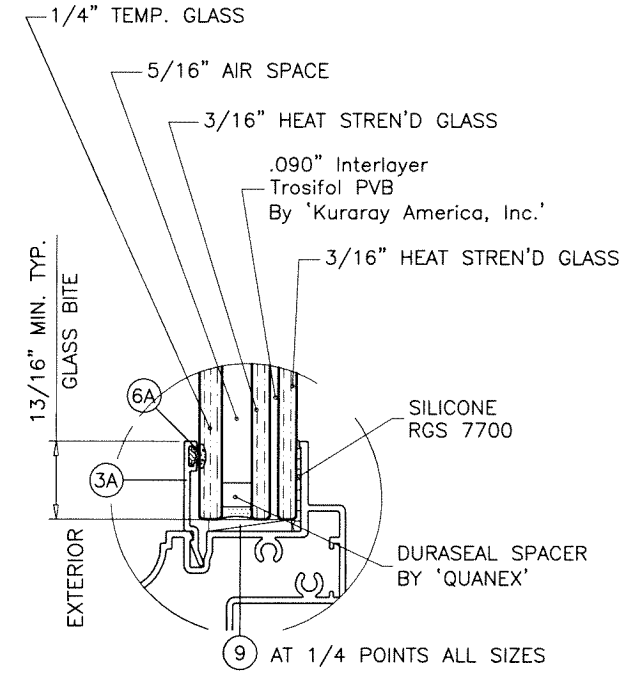

GLASS TYPE 'C'
1" OVERALL INSUL. LAM. GLASS

GLAZING OPTIONS

THESE WINDOWS ARE RATED FOR LARGE & SMALL MISSILE IMPACT. SHUTTERS ARE NOT REQUIRED.

SERIES 525 ALUMINUM CASEMENT WINDOW

APPROVAL APPLIES TO SINGLE UNITS OR SIDE BY SIDE COMBINATIONS OF CASMT/CASMT OR CASEMENT WITH OTHER F.B.C. APPR'D WINDOWS USING F.B.C. APPROVED MULLIONS IN BETWEEN. LOWER DESIGN PRESSURE FROM WINDOWS OR MULLION APPROVAL WILL APPLY TO ENTIRE SYSTEM.

THIS PRODUCT HAS BEEN DESIGNED AND TESTED TO COMPLY WITH THE REQUIREMENTS OF THE 2020 (7TH EDITION)/2023 (8TH EDITION) FLORIDA BUILDING CODE INCLUDING HIGH VELOCITY HURRICANE ZONE (HVHZ).

1BY OR 2BY WOOD BUCKS & BUCK FASTENERS BY OTHERS, MUST BE DESIGNED AND INSTALLED ADEQUATELY TO TRANSFER APPLIED PRODUCT LOADS TO THE BUILDING STRUCTURE.

ANCHORS SHALL BE CORROSION RESISTANT, SPACED AS SHOWN ON DETAILS AND INSTALLED PER MANUF'S INSTRUCTIONS. SPECIFIED EMBEDMENT TO BASE MATERIAL SHALL BE BEYOND WALL DRESSING OR STUCCO.

A LOAD DURATION INCREASE IS USED IN DESIGN OF ANCHORS INTO WOOD ONLY.

ALL SHIMS TO BE HIGH IMPACT, NON-METALLIC AND NON-COMPRESSIBLE.

MATERIALS INCLUDING BUT NOT LIMITED TO STEEL/METAL SCREWS, THAT COME INTO CONTACT WITH OTHER DISSIMILAR MATERIALS SHALL MEET THE REQUIREMENTS OF THE 2020/2023 FLORIDA BLDG. CODE & ADOPTED STANDARDS.

THIS PRODUCT APPROVAL IS GENERIC AND DOES NOT PROVIDE INFORMATION FOR A SITE SPECIFIC PROJECT, I.E. LIFE SAFETY OF THIS PRODUCT, ADEQUACY OF STRUCTURE RECEIVING THIS PRODUCT AND SEALING AROUND OPENING FOR WATER INFILTRATION RESISTANCE ETC. CONDITIONS NOT SHOWN IN THIS DRAWING ARE TO BE ANALYZED SEPARATELY, AND TO BE REVIEWED BY BUILDING OFFICIAL.

DESIGN LOADS SHOWN ARE BASED ON 'ALLOWABLE STRESS DESIGN (ASD)'.

MANUFACTURER'S LABEL SHALL BE LOCATED ON A READILY VISIBLE LOCATION IN ACCORDANCE WITH SECTION 1709.9.3 OF FLORIDA BUILDING CODE. LABELING TO COMPLY WITH SECTION 1709.9.2.

NOTE: GLASS CAPACITIES ON THIS SHEET ARE BASED ON ASTM E1300-09 (3 SEC. GUSTS) AND FLORIDA BUILDING COMMISSION DECLARATORY STATEMENT DCA05-DEC-219

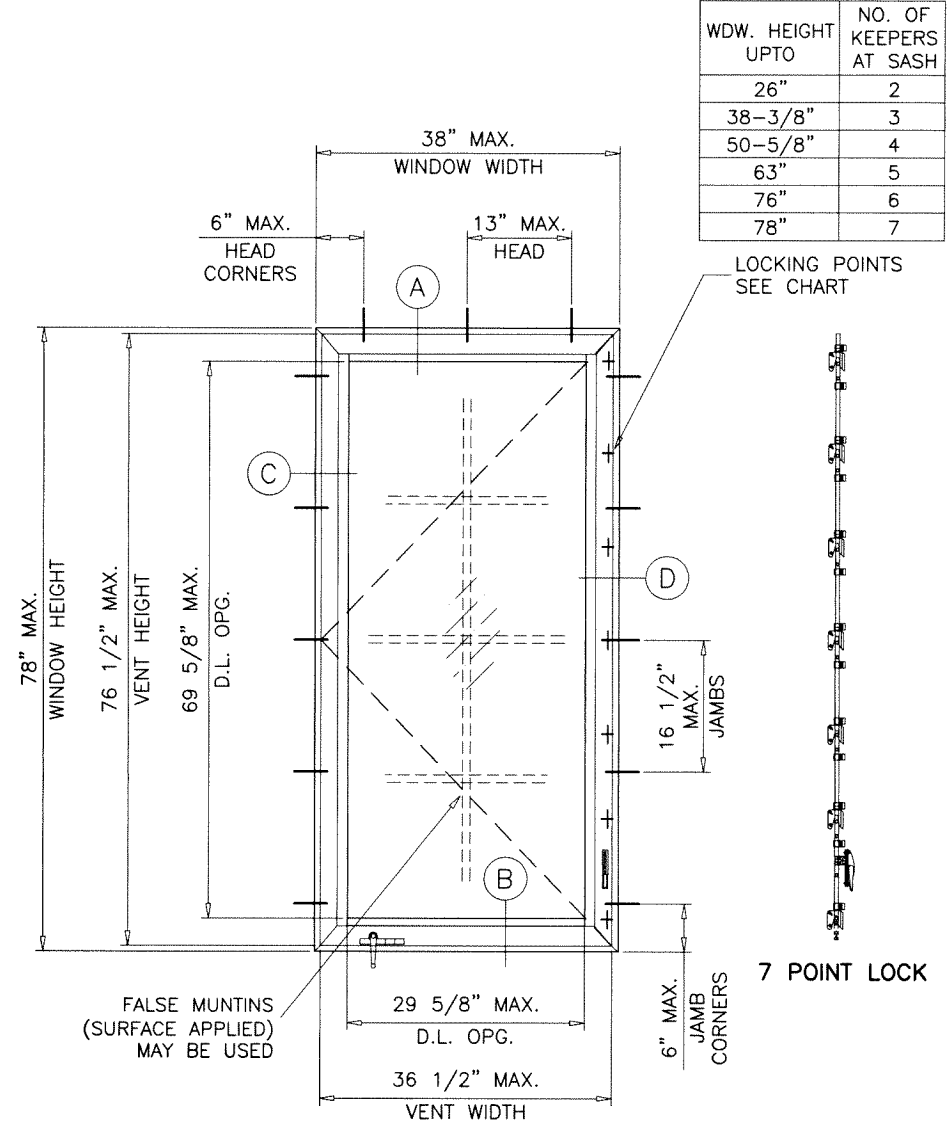

TYPICAL ELEVATION

GLASS TYPES 'A', 'B' OR 'C'
MAXIMUM DESIGN LOAD RATING = + 70.0 PSF
(FOR SIZES SHOWN ABOVE OR SMALLER) - 75.0 PSF

DAYLITE OPENINGS:
D.L.O. HEIGHT = WINDOW HEIGHT - 8.375"
D.L.O. WIDTH = WINDOW WIDTH - 8.375"
VENT HEIGHT = WINDOW HEIGHT - 1.50"
VENT WIDTH = WINDOW WIDTH - 1.50"

Sealed: 7/20/2023

FL #21898

A- CONTRACTOR TO BE RESPONSIBLE FOR THE SELECTION, PURCHASE AND INSTALLATION OF THIS PRODUCT BASED ON THIS PRODUCT EVALUATION PROVIDED HE/SHE DOES NOT DEVIATE FROM THE CONDITIONS DETAILED ON THIS DOCUMENT.
B- THIS PRODUCT EVALUATION DOCUMENT WILL BE CONSIDERED INVALID IF ALTERED BY ANY MEANS.
C- SITE SPECIFIC PROJECTS SHALL BE PREPARED BY A FLORIDA REGISTERED ENGINEER OR ARCHITECT WHICH WILL BECOME THE ENGINEER OF RECORD (E.O.R.) FOR THE PROJECT AND WHO WILL BE RESPONSIBLE FOR THE PROPER USE OF THE P.E.D. ENGINEER OF RECORD, ACTING AS A DELEGATED ENGINEER TO THE P.E.D. ENGINEER SHALL SUBMIT TO THIS LATTER THE SITE SPECIFIC DRAWINGS FOR REVIEW.
D- THIS P.E.D. SHALL BEAR THE DATE AND ORIGINAL SEAL AND SIGNATURE OF THE PROFESSIONAL ENGINEER OF RECORD THAT PREPARED IT.



WDW. HEIGHT UPTO	NO. OF KEEPERS AT SASH
26"	2
38-3/8"	3
50-5/8"	4
63"	5
76"	6
78"	7

AL-FAROOQ CORPORATION
ENGINEERS & PRODUCT DEVELOPMENT
9360 SUNSET DRIVE, SUITE 220
MIAMI, FLORIDA 333173
TEL. (305) 264-8100 FAX. (305) 262-6978
COMP-ANL W17-20AW

SERIES 525 ALUMINUM CASEMENT WDW. (L.M.I.)
Assura Windows & Doors, LLC.
1543 N. Powerline Road
Pompano Beach, FL. 33069
Tel. (954) 781-4430
www.assurawindows.com

no	date	by	description
A	10.09.17		UPDATED TO 2017 FBC
B	07.05.23		UPDATED TO 2023 FBC

date: 02-10-17
scale: 1/2"=1'-0"
dr. by: TARIQ
chk. by:

drawing no. **W17-20**
sheet 1 of 5

ITEM	PART #	QUANTITY	DESCRIPTION	MATERIAL	MANF./SUPPLIER/REMARKS
1	TM-358	4	WINDOW FRAME	6063-T6	-
2	TM-359	4	WINDOW VENT	6063-T6	-
3	TM-327	4	GLAZING BEAD (LAM. GLASS)	6063-T6	-
3A	TM-326	4	GLAZING BEAD (INSUL. LAM. GLASS)	6063-T6	-
4	#10 X 1"	2/ CORNER	ASSEMBLY FASTENERS	CRS	PH SMS
5	-	1/ CORNER	CORNER KEY, .060" THK.	ALUMINUM	-
5A	-	1/ CORNER	CORNER KEY, .060" THK.	ALUMINUM	-
6	32001	AS REQD.	GLAZING SPACER (FOAM FILLED BULB) (LAM. GLASS)	TPE POLYPROPYLENE	DUROMETER 70±5 SHORE A
6A	32011	AS REQD.	GLAZING SPACER (FOAM FILLED BULB) (INSUL. LAM. GLASS)	TPE POLYPROPYLENE	DUROMETER 70±5 SHORE A
7	QEZD 250	AS REQD.	VENT INTERIOR W'STRIPPING	-	AMESBURY
8	12298	AS REQD.	FRAME W'STRIPPING	-	AMESBURY
9	-	2/ LITE	SETTING BLOCK, AT 1/4 POINTS	EPDM	DUROMETER 85±5 SHORE A
10	OP10603G	1	DUAL ARM OPERATOR	-	RADISSON IND.
11	PO-2301	1	MULTIPOINT LOCKING HANDLE	-	RADISSON IND.
12	316	2	3000 SERIES 4-BAR PROJECTION HINGES	-	ADVANTAGE MANUF. CORP.
13	1549-3	-	SNUBBER	-	ADVANTAGE MANUF. CORP.

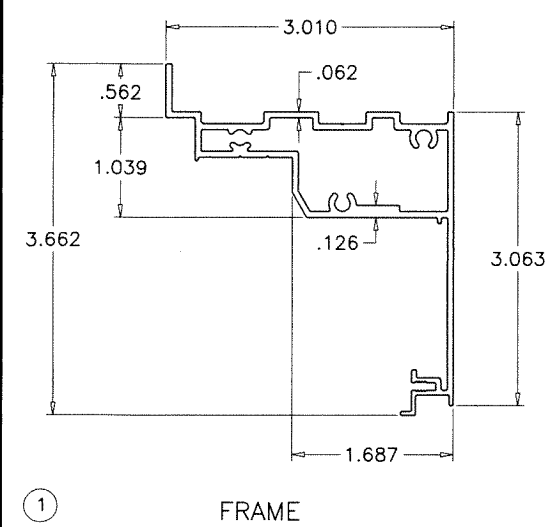

① FRAME

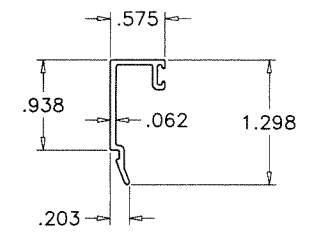

③ GLAZING BEAD (LAM. GLASS)

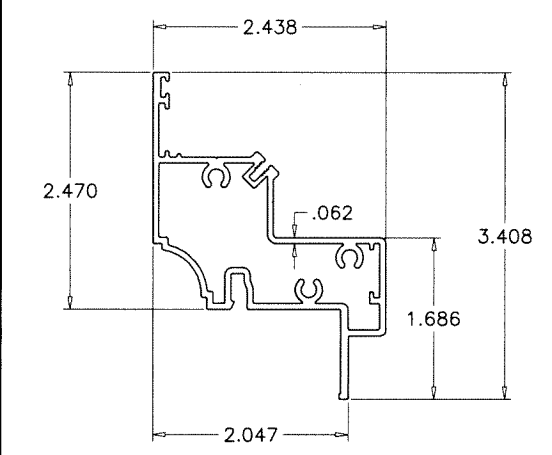

② VENT

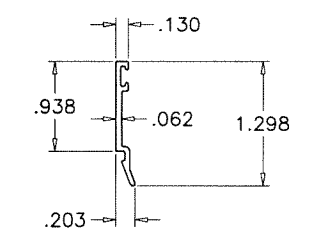

③A GLAZING BEAD (INSUL. LAM. GLASS)

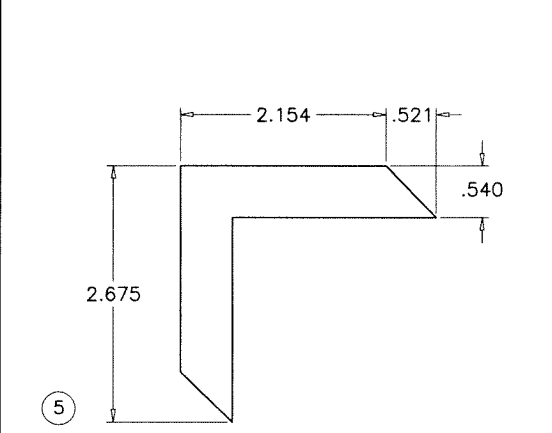

⑤ CORNER KEYS

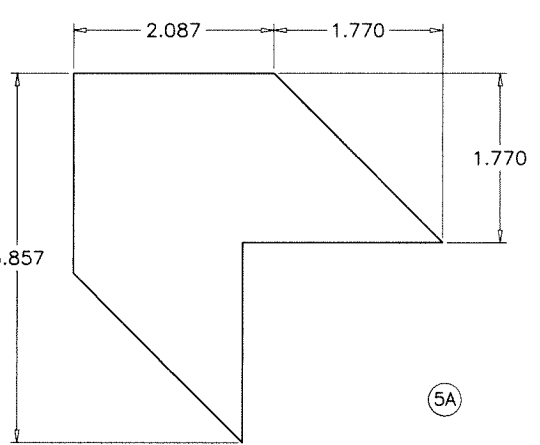

⑤A

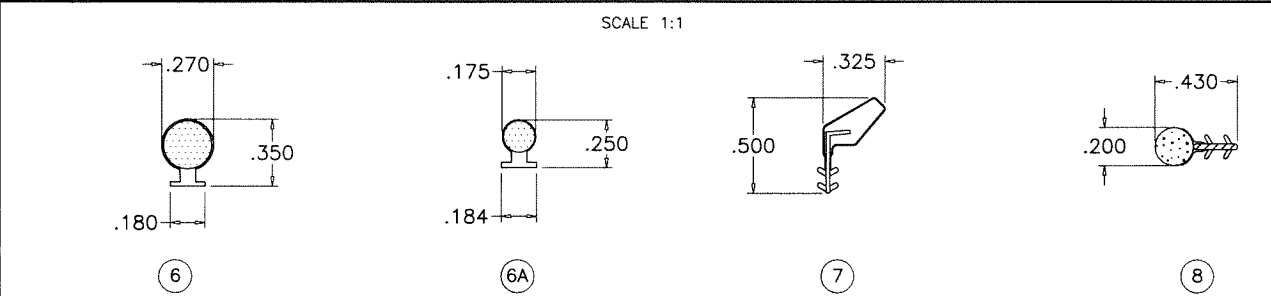

⑥ VENT EXTERIOR W'STRIPPING
 ⑥A GLAZING SPACER (LAM. GLASS)
 ⑦ GLAZING SPACER (INSUL. LAM. GLASS)
 ⑧ VENT INTERIOR W'STRIPPING
 ⑧ FRAME W'STRIPPING

SEALANT:

ALL JOINTS AND FRAME CONNECTIONS SEALED WITH CRL SMALL JOINT SEAM SEALER.

HINGES:

SERIES 3000 MAGNUM 4 BAR OFFSET HINGES BY 'ADVANTAGE MANUF. CORP.' LOCATED AT TOP AND BOTTOM CORNERS FASTENED TO FRAME WITH (3) #10 X 3/8" PH SMS FASTENED TO VENT WITH (5) #10 X 1/2" PH SMS

LOCKS:

7 POINT LOCK SYSTEM BY 'RADISSON IND.' AT FRAME JAMB LOCK OPERATOR AT 6-3/4" FROM SILL HANDLE SECURED TO FRAME WITH (2) #10 X 1/2" PH MS LOCK BAR SECURED TO FRAME WITH (9) UNIFORMLY SPACED LOCK GUIDES, EACH ATTACHED WITH (2) #8 X 3/4" FH TEKS STRIKERS FACING LOCKING POINTS ATTACHED TO VENT WITH (5) #10 X 1/2" FH SCREWS

OPERATOR:

DUAL ARM OPERATOR OP10603G BY 'RADISSON IND.' LOCATED AT SILL END SECURED TO FRAME SILL WITH (2) #10 X 5/8" FH SMS OPERATOR ARM SECURED TO VENT WITH (3) #8 X 3/4" FH SMS PIVOT ARM SECURED TO VENT WITH (3) #8 X 3/4" FH SMS

SNUBBERS:

SERIES 6000 ALUMINUM SNUBBERS BY 'ADVANTAGE MANUF. CORP.' AT 6" FROM ENDS AND 39" O.C. (3) DRIVERS AT VENT EACH SECURED WITH (3) #10 X 5/8" FH SMS (3) RECIEVERS AT FRAME EACH SECURED WITH (2) #10 X 5/8" FH SMS

Sealed: 7/20/2023

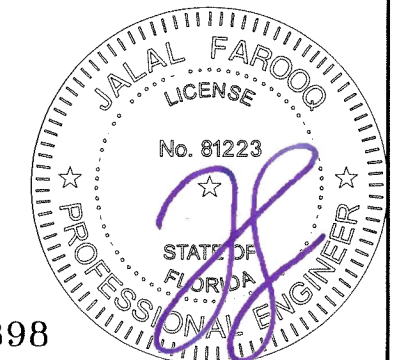

FL #21898

AL-FAROOQ CORPORATION
 ENGINEERS & PRODUCT DEVELOPMENT
 9360 SUNSET DRIVE, SUITE 220
 MIAMI, FLORIDA 33173 (C.A.N. 3538)
 TEL. (305) 264-8100 FAX. (305) 262-6978
 COMP-ANL\W17-20AW

SERIES 525 ALUMINUM CASEMENT WDW. (L.M.I.)
Assura Windows & Doors, LLC.
 1543 N. Powerline Road
 Pompano Beach, FL. 33069
 Tel. (954) 781-4430 www.gssurawindows.com

revisions:	no	date	by	description

date: 02-10-17
 scale: 1/2" = 1"
 dr. by: TARIQ
 chk. by:
 drawing no. W17-20
 sheet 4 of 5

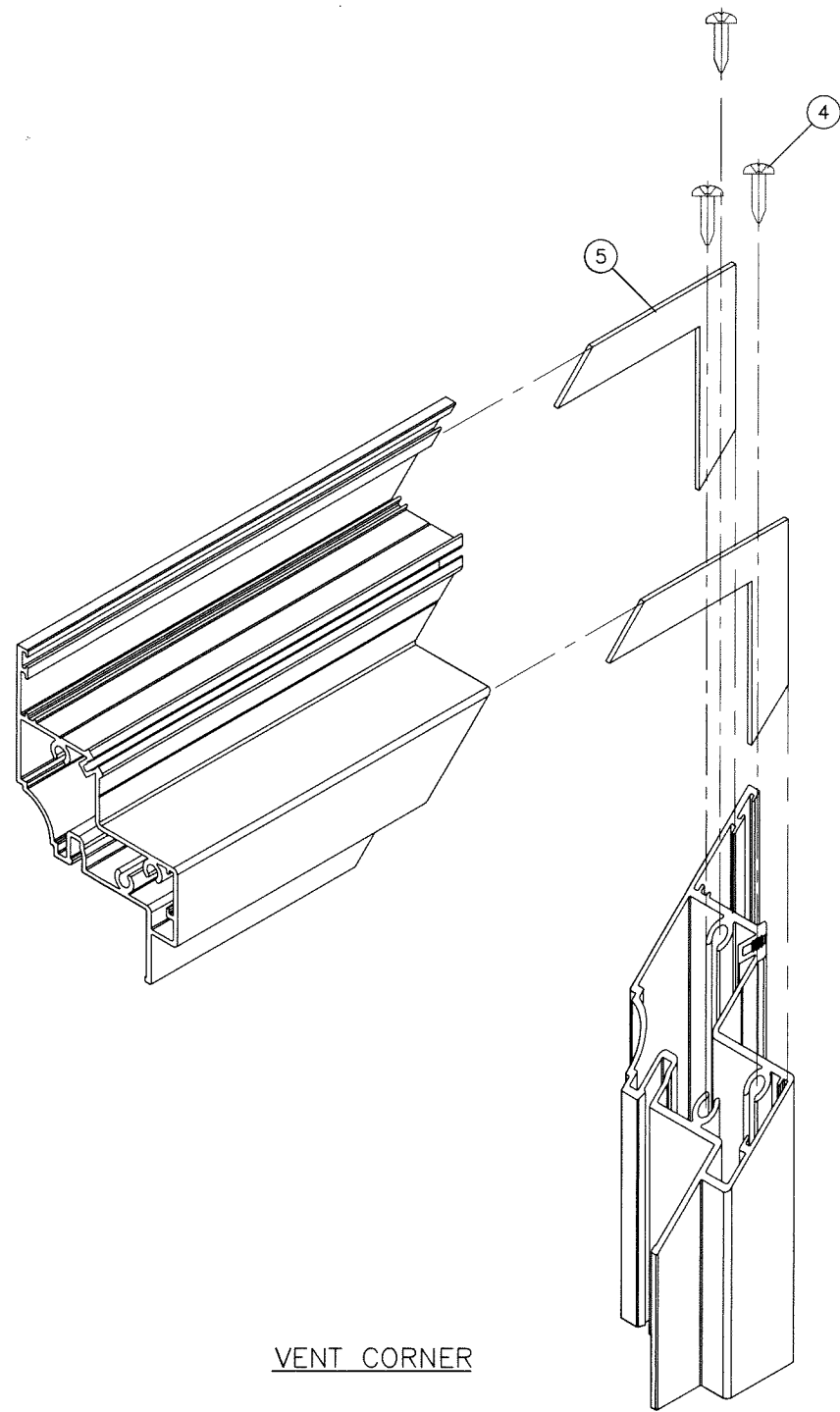

VENT CORNER

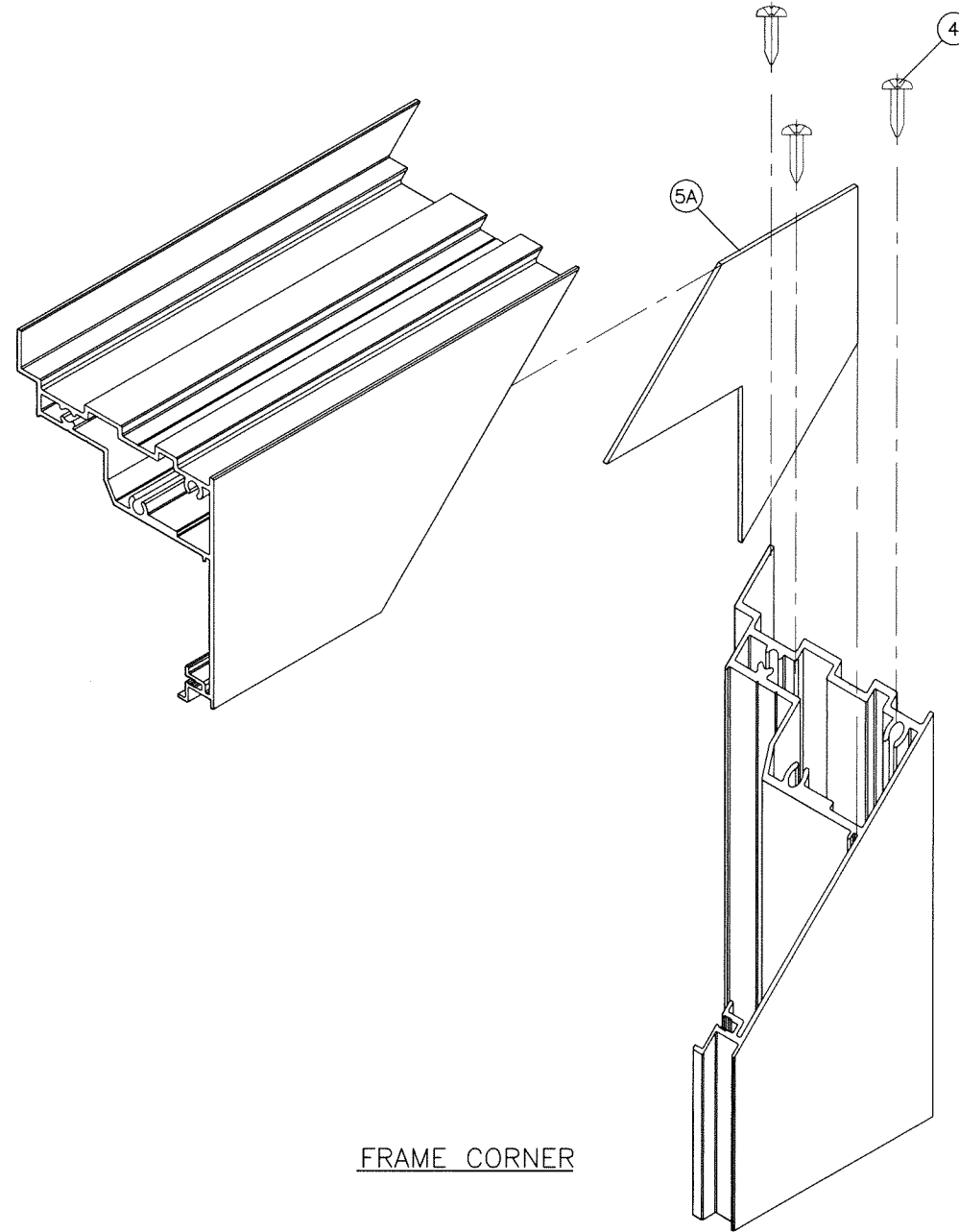

FRAME CORNER

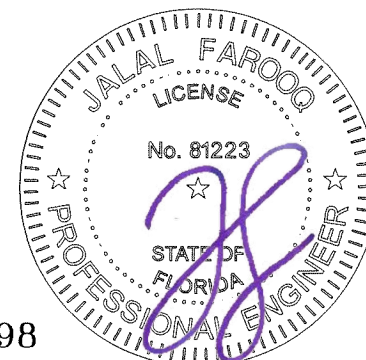

Sealed: 7/20/2023

FL #21898



AL-FAROOQ CORPORATION
 ENGINEERS & PRODUCT DEVELOPMENT
 9360 SUNSET DRIVE, SUITE 220
 MIAMI, FLORIDA 33173 (C.A.N. 3538)
 TEL. (305) 264-8100 FAX. (305) 262-6978

COMP-ANL\W17-20AW

SERIES 525 ALUMINUM CASEMENT WDW. (L.M.I.)

Assura Windows & Doors, LLC.
 1543 N. Powerline Road
 Pompano Beach, FL. 33069
 Tel. (954) 781-4430 www.assurawindows.com

revisions:	
no	date by description

date: 02-10-17
 scale: 1/2" = 1"
 dr. by: TARIQ
 chk. by:

drawing no.
W17-20

sheet 5 of 5