

THESE WINDOWS ARE RATED FOR LARGE & SMALL MISSILE IMPACT. SHUTTERS ARE NOT REQUIRED.

SERIES 605 ALUMINUM SINGLE HUNG WINDOW

DESIGN LOAD RATINGS FOR THESE WINDOWS TO BE AS PER CHARTS SHOWN ON SHEET 2.

APPROVAL APPLIES TO SINGLE UNITS OR SIDE BY SIDE COMBINATIONS OF S.H./S.H. OR SINGLE HUNG WITH OTHER WINDOW TYPES IN MODULES OF TWO OR MORE WINDOWS USING F.B.C. APPROVED MULLIONS IN BETWEEN. LOWER DESIGN PRESSURE FROM WINDOWS OR MULLION APPROVAL WILL APPLY TO ENTIRE SYSTEM.

THIS PRODUCT HAS BEEN DESIGNED AND TESTED TO COMPLY WITH THE REQUIREMENTS OF THE 2020 (7TH EDITION)/2023 (8TH EDITION) FLORIDA BUILDING CODE INCLUDING HIGH VELOCITY HURRICANE ZONE (HVHZ).

1BY OR 2BY WOOD BUCKS & BUCK FASTENERS BY OTHERS, MUST BE DESIGNED AND INSTALLED ADEQUATELY TO TRANSFER APPLIED PRODUCT LOADS TO THE BUILDING STRUCTURE.

ANCHORS SHALL BE CORROSION RESISTANT, SPACED AS SHOWN ON DETAILS AND INSTALLED PER MANUF'S INSTRUCTIONS. SPECIFIED EMBEDMENT TO BASE MATERIAL SHALL BE BEYOND WALL DRESSING OR STUCCO.

A LOAD DURATION INCREASE IS USED IN DESIGN OF ANCHORS INTO WOOD ONLY. ALL SHIMS TO BE HIGH IMPACT, NON-METALLIC AND NON-COMPRESSIBLE.

MATERIALS INCLUDING BUT NOT LIMITED TO STEEL/METAL SCREWS, THAT COME INTO CONTACT WITH OTHER DISSIMILAR MATERIALS SHALL MEET THE REQUIREMENTS OF THE 2020/2023 FLORIDA BLDG. CODE & ADOPTED STANDARDS.

THIS PRODUCT APPROVAL IS GENERIC AND DOES NOT PROVIDE INFORMATION FOR A SITE SPECIFIC PROJECT, i.e. LIFE SAFETY OF THIS PRODUCT, ADEQUACY OF STRUCTURE RECEIVING THIS PRODUCT AND SEALING AROUND OPENING FOR WATER INFILTRATION RESISTANCE ETC.

CONDITIONS NOT SHOWN IN THIS DRAWING ARE TO BE ANALYZED SEPARATELY, AND TO BE REVIEWED BY BUILDING OFFICIAL.

DESIGN LOADS SHOWN ARE BASED ON 'ALLOWABLE STRESS DESIGN (ASD)'.

MANUFACTURER'S LABEL SHALL BE LOCATED ON A READILY VISIBLE LOCATION IN ACCORDANCE WITH SECTION 1709.9.3 OF FLORIDA BUILDING CODE. LABELING TO COMPLY WITH SECTION 1709.9.2.

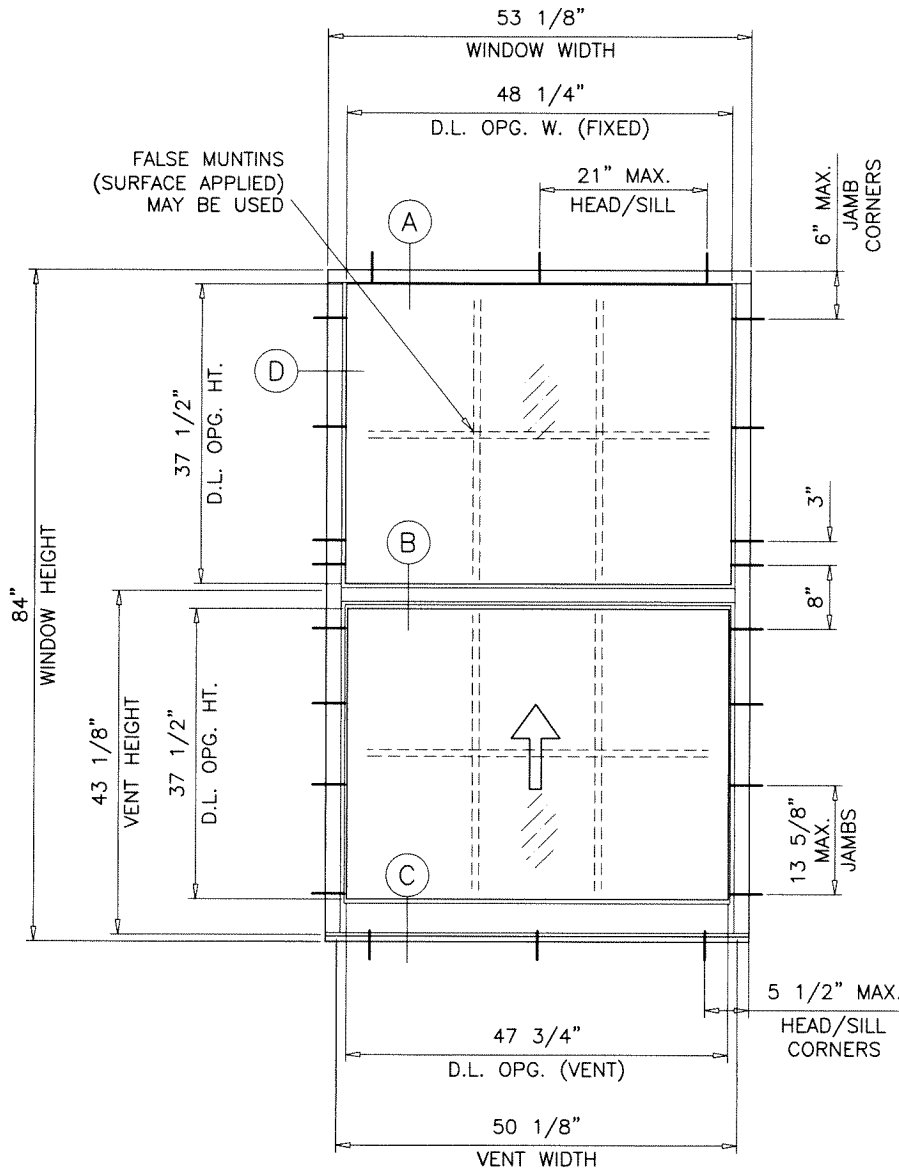

**TYPICAL ELEVATION
EQUAL LITES
(SEE DESIGN CAPACITY CHART)**

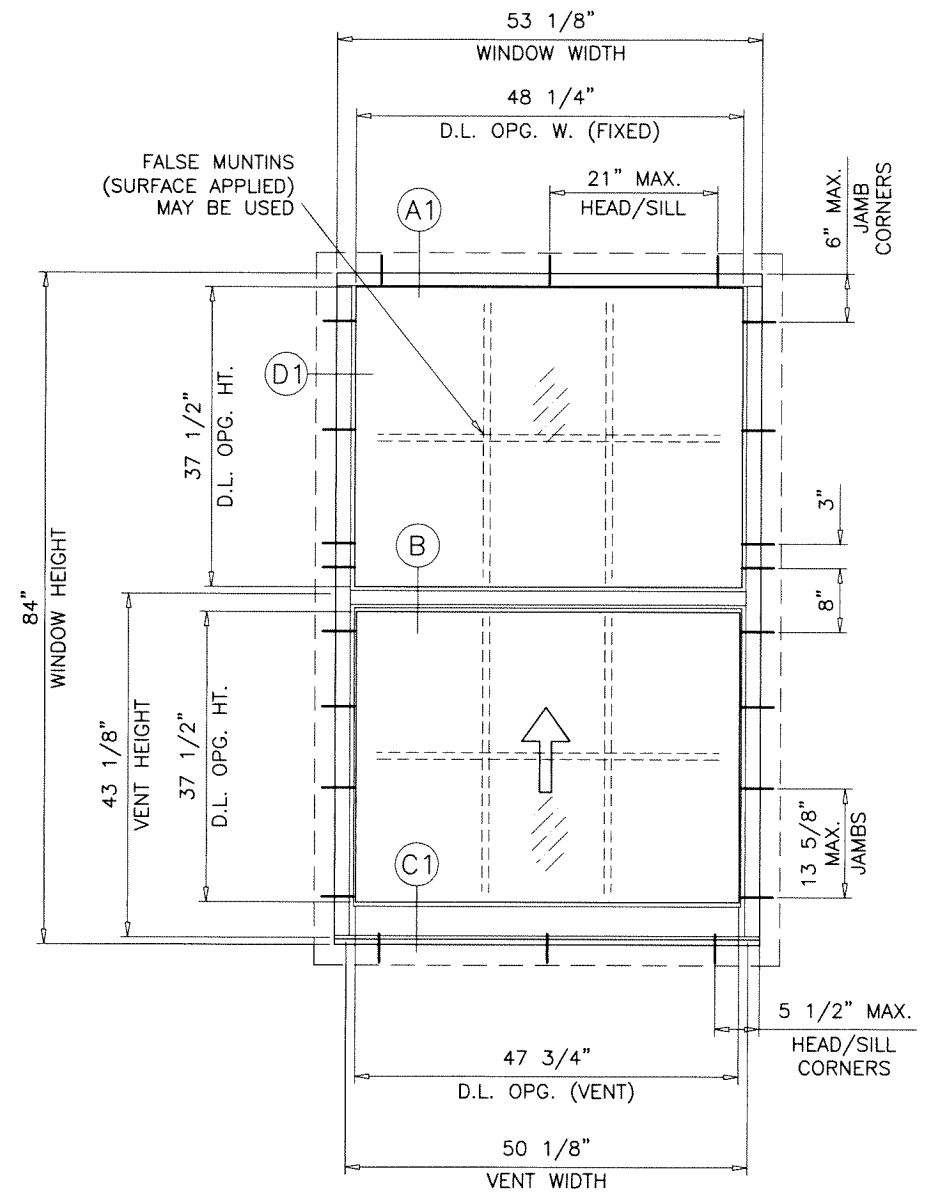

**TYPICAL ELEVATION
WITH OPTIONAL FIN
EQUAL LITES
(LIMIT DESIGN CAPACITY TO ±61.0 PSF MAX.)**

D.L.O. WIDTH (FIXED) = WINDOW WIDTH - 4.875"
D.L.O. WIDTH (VENT) = WINDOW WIDTH - 5.375"
D.L.O. HEIGHT = WINDOW HEIGHT/2 - 4.5"

**LAMINATED GLASS
INSUL. LAM. GLASS
LARGE MISSILE IMPACT**

Sealed: 7/20/2023

FL #21857

- A- CONTRACTOR TO BE RESPONSIBLE FOR THE SELECTION, PURCHASE AND INSTALLATION OF THIS PRODUCT BASED ON THIS PRODUCT EVALUATION PROVIDED HE/SHE DOES NOT DEVIATE FROM THE CONDITIONS DETAILED ON THIS DOCUMENT.
- B- THIS PRODUCT EVALUATION DOCUMENT WILL BE CONSIDERED INVALID IF ALTERED BY ANY MEANS.
- C- SITE SPECIFIC PROJECTS SHALL BE PREPARED BY A FLORIDA REGISTERED ENGINEER OR ARCHITECT WHICH WILL BECOME THE ENGINEER OF RECORD (E.O.R.) FOR THE PROJECT AND WHO WILL BE RESPONSIBLE FOR THE PROPER USE OF THE P.E.D. ENGINEER OF RECORD, ACTING AS A DELEGATED ENGINEER TO THE P.E.D. ENGINEER SHALL SUBMIT TO THIS LATTER THE SITE SPECIFIC DRAWINGS FOR REVIEW.
- D- THIS P.E.D. SHALL BEAR THE DATE AND ORIGINAL SEAL AND SIGNATURE OF THE PROFESSIONAL ENGINEER OF RECORD THAT PREPARED IT.

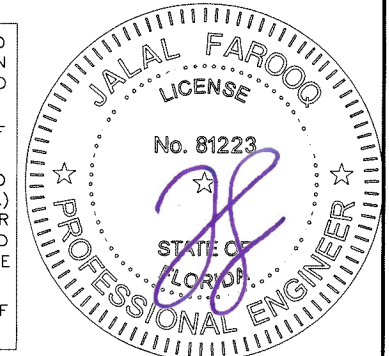

af c
AL-FAROOQ CORPORATION
ENGINEERS & PRODUCT DEVELOPMENT
9360 SUNSET DRIVE, SUITE 220
MIAMI, FLORIDA 33173 (C.A.N. 3538)
TEL. (305) 264-8100 FAX. (305) 262-6978
COMP-ANL\W15-28TMW

SERIES 605 ALUMINUM SINGLE HUNG WDW. (L.M.I.)
Assura Windows & Doors, LLC.
1543 N. Powerline Road
Pompano Beach, FL. 33069
Tel. (954) 781-4430 www.assurawindows.com

no	date	description
A	02.08.17	MANUF. NAME REV.
B	10.05.17	UPDATED TO 2017 FBC
C	09.23.20	UPDATED TO 2020 FBC
D	07.03.23	UPDATED TO 2023 FBC

revisions:

date: 06-29-15
scale: 1/2"=1'-0"
dr. by: TARIQ
chk. by:

drawing no.
W15-28
sheet 1 of 7

DESIGN LOAD CAPACITY - PSF
(WITH ALUMINUM REINFORCING)

WINDOW DIMS.		GLASS TYPE 'C'		GLASS TYPES 'D' & 'E'		GLASS TYPE 'F'		GLASS TYPE 'G'		GLASS TYPE 'H'		GLASS TYPE 'I'		GLASS TYPE 'J'		
WIDTH	HEIGHT	EXT.(+)	1NT.(-)	EXT.(+)	1NT.(-)	EXT.(+)	1NT.(-)	EXT.(+)	1NT.(-)	EXT.(+)	1NT.(-)	EXT.(+)	1NT.(-)	EXT.(+)	1NT.(-)	
19-1/8"	26" (4)	70.0	70.0	61.0	61.0	80.0	80.0	80.0	80.0	80.0	80.0	80.0	80.0	80.0	80.0	
26-1/2"		70.0	70.0	61.0	61.0	80.0	80.0	80.0	80.0	80.0	80.0	80.0	80.0	80.0	80.0	
37"		70.0	70.0	61.0	61.0	80.0	80.0	80.0	80.0	80.0	80.0	80.0	80.0	80.0	80.0	
53-1/8"		70.0	70.0	61.0	61.0	80.0	80.0	80.0	80.0	80.0	80.0	80.0	80.0	80.0	80.0	
19-1/8"	38-3/8" (4)	70.0	70.0	61.0	61.0	80.0	80.0	80.0	80.0	80.0	80.0	80.0	80.0	80.0	80.0	
26-1/2"		70.0	70.0	61.0	61.0	80.0	80.0	80.0	80.0	80.0	80.0	80.0	80.0	80.0	80.0	
37"		70.0	70.0	61.0	61.0	80.0	80.0	80.0	80.0	80.0	80.0	80.0	80.0	80.0	80.0	
53-1/8"		70.0	70.0	61.0	61.0	80.0	80.0	80.0	80.0	80.0	80.0	80.0	80.0	80.0	80.0	
19-1/8"	50-5/8" (5)	70.0	70.0	61.0	61.0	80.0	80.0	80.0	80.0	80.0	80.0	80.0	80.0	80.0	80.0	
26-1/2"		70.0	70.0	61.0	61.0	80.0	80.0	80.0	80.0	80.0	80.0	80.0	80.0	80.0	80.0	
37"		70.0	70.0	61.0	61.0	80.0	80.0	80.0	80.0	80.0	80.0	80.0	80.0	80.0	80.0	
53-1/8"		70.0	70.0	61.0	61.0	80.0	80.0	80.0	80.0	80.0	80.0	80.0	80.0	80.0	80.0	
19-1/8"	56-5/8" (6)	70.0	70.0	61.0	61.0	80.0	80.0	80.0	80.0	80.0	80.0	80.0	80.0	80.0	80.0	
26-1/2"		70.0	70.0	61.0	61.0	80.0	80.0	80.0	80.0	80.0	80.0	80.0	80.0	80.0	80.0	
37"		70.0	70.0	61.0	61.0	80.0	80.0	80.0	80.0	80.0	80.0	80.0	80.0	80.0	80.0	
53-1/8"		70.0	70.0	61.0	61.0	80.0	80.0	80.0	80.0	80.0	80.0	80.0	80.0	80.0	80.0	
19-1/8"	63" (6)	70.0	70.0	61.0	61.0	80.0	80.0	80.0	80.0	80.0	80.0	80.0	80.0	80.0	80.0	
26-1/2"		70.0	70.0	61.0	61.0	80.0	80.0	80.0	80.0	80.0	80.0	80.0	80.0	80.0	80.0	
37"		70.0	70.0	61.0	61.0	80.0	80.0	80.0	80.0	80.0	80.0	80.0	80.0	80.0	80.0	
53-1/8"		70.0	70.0	61.0	61.0	80.0	80.0	80.0	80.0	80.0	80.0	80.0	80.0	80.0	80.0	
19-1/8"	72" (7)	70.0	70.0	61.0	61.0	80.0	80.0	80.0	80.0	80.0	80.0	80.0	80.0	80.0	80.0	
26-1/2"		70.0	70.0	61.0	61.0	80.0	80.0	80.0	80.0	80.0	80.0	80.0	80.0	80.0	80.0	
37"		70.0	70.0	61.0	61.0	80.0	80.0	80.0	80.0	80.0	80.0	80.0	80.0	80.0	80.0	
53-1/8"		-	-	61.0	61.0	-	-	80.0	80.0	80.0	80.0	78.2	78.2	80.0	80.0	80.0
19-1/8"	76-3/4" (7)	70.0	70.0	61.0	61.0	80.0	80.0	80.0	80.0	80.0	80.0	80.0	80.0	80.0	80.0	
26-1/2"		70.0	70.0	61.0	61.0	80.0	80.0	80.0	80.0	80.0	80.0	80.0	80.0	80.0	80.0	
37"		70.0	70.0	61.0	61.0	80.0	80.0	80.0	80.0	80.0	80.0	80.0	80.0	80.0	80.0	
53-1/8"		-	-	61.0	61.0	-	-	77.6	77.6	80.0	80.0	74.5	74.5	80.0	80.0	80.0
24"	48" (5)	70.0	70.0	61.0	61.0	80.0	80.0	80.0	80.0	80.0	80.0	80.0	80.0	80.0	80.0	
30"		70.0	70.0	61.0	61.0	80.0	80.0	80.0	80.0	80.0	80.0	80.0	80.0	80.0	80.0	
36"		70.0	70.0	61.0	61.0	80.0	80.0	80.0	80.0	80.0	80.0	80.0	80.0	80.0	80.0	
42"		70.0	70.0	61.0	61.0	80.0	80.0	80.0	80.0	80.0	80.0	80.0	80.0	80.0	80.0	
48"		70.0	70.0	61.0	61.0	80.0	80.0	80.0	80.0	80.0	80.0	80.0	80.0	80.0	80.0	
54"		70.0	70.0	61.0	61.0	80.0	80.0	80.0	80.0	80.0	80.0	80.0	80.0	80.0	80.0	
24"	60" (6)	70.0	70.0	61.0	61.0	80.0	80.0	80.0	80.0	80.0	80.0	80.0	80.0	80.0	80.0	
30"		70.0	70.0	61.0	61.0	80.0	80.0	80.0	80.0	80.0	80.0	80.0	80.0	80.0	80.0	
36"		70.0	70.0	61.0	61.0	80.0	80.0	80.0	80.0	80.0	80.0	80.0	80.0	80.0	80.0	
42"		70.0	70.0	61.0	61.0	80.0	80.0	80.0	80.0	80.0	80.0	80.0	80.0	80.0	80.0	
48"		70.0	70.0	61.0	61.0	80.0	80.0	80.0	80.0	80.0	80.0	80.0	80.0	80.0	80.0	
54"		70.0	70.0	61.0	61.0	80.0	80.0	80.0	80.0	80.0	80.0	80.0	80.0	80.0	80.0	
24"	72" (7)	70.0	70.0	61.0	61.0	80.0	80.0	80.0	80.0	80.0	80.0	80.0	80.0	80.0	80.0	
30"		70.0	70.0	61.0	61.0	80.0	80.0	80.0	80.0	80.0	80.0	80.0	80.0	80.0	80.0	
36"		70.0	70.0	61.0	61.0	80.0	80.0	80.0	80.0	80.0	80.0	80.0	80.0	80.0	80.0	
42"		70.0	70.0	61.0	61.0	80.0	80.0	80.0	80.0	80.0	80.0	80.0	80.0	80.0	80.0	
48"		-	-	61.0	61.0	-	-	80.0	80.0	80.0	80.0	80.0	80.0	80.0	80.0	80.0
54"		-	-	61.0	61.0	-	-	79.1	79.1	79.1	79.1	76.8	76.8	78.4	78.4	80.0
24"	84" (8)	70.0	70.0	61.0	61.0	80.0	80.0	80.0	80.0	80.0	80.0	80.0	80.0	80.0	80.0	
30"		70.0	70.0	61.0	61.0	80.0	80.0	80.0	80.0	80.0	80.0	80.0	80.0	80.0	80.0	
36"		-	-	61.0	61.0	-	-	80.0	80.0	80.0	80.0	80.0	80.0	80.0	80.0	80.0
42"		-	-	61.0	61.0	-	-	80.0	80.0	80.0	80.0	80.0	80.0	80.0	80.0	80.0
48"		-	-	61.0	61.0	-	-	80.0	80.0	80.0	80.0	77.5	77.5	80.0	80.0	80.0

() NO. IN PARENTHESIS INDICATE NO. OF ANCHORS PER JAMB

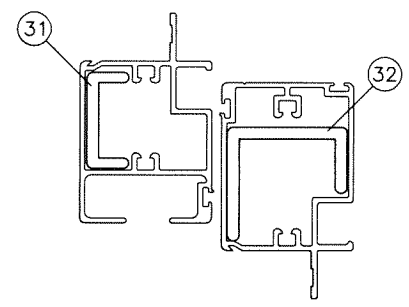

DESIGN LOAD CAPACITY - PSF
(WITH STEEL REINFORCING)

WINDOW DIMS.		GLASS TYPE 'F'	
WIDTH	HEIGHT	EXT.(+)	1NT.(-)
19-1/8"	26" (4)	80.0	115.0
26-1/2"		80.0	115.0
37"		80.0	115.0
53-1/8"		80.0	115.0
19-1/8"	38-3/8" (4)	80.0	115.0
26-1/2"		80.0	115.0
37"		80.0	115.0
53-1/8"		80.0	115.0
19-1/8"	50-5/8" (5)	80.0	115.0
26-1/2"		80.0	115.0
37"		80.0	115.0
53-1/8"		80.0	115.0
19-1/8"	56-5/8" (6)	80.0	115.0
26-1/2"		80.0	115.0
37"		80.0	115.0
53-1/8"		80.0	115.0
19-1/8"	63" (6)	80.0	115.0
26-1/2"		80.0	115.0
37"		80.0	115.0
53-1/8"		80.0	115.0
19-1/8"	72" (7)	80.0	115.0
26-1/2"		80.0	115.0
37"		80.0	115.0
53-1/8"		80.0	115.0
19-1/8"	76-3/4" (7)	80.0	115.0
26-1/2"		80.0	115.0
37"		80.0	112.2
24"	48" (5)	80.0	115.0
30"		80.0	115.0
36"		80.0	115.0
42"		80.0	115.0
48"		80.0	115.0
54"	80.0	109.1	
24"	60" (6)	80.0	115.0
30"		80.0	115.0
36"		80.0	115.0
42"		80.0	115.0
48"		80.0	109.7
54"	80.0	98.4	
24"	72" (7)	80.0	115.0
30"		80.0	115.0
42"		80.0	112.0
24"	84" (8)	80.0	115.0
30"		80.0	115.0

() NO. IN PARENTHESIS INDICATE NO. OF ANCHORS PER JAMB

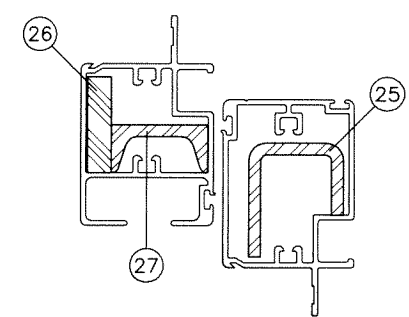

NOTE:
GLASS CAPACITIES ON THIS SHEET ARE
BASED ON ASTM E1300-09 (3 SEC. GUSTS)
AND FLORIDA BUILDING COMMISSION
DECLARATORY STATEMENT DCA05-DEC-219

Sealed: 7/20/2023

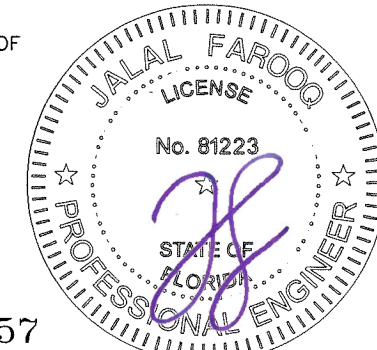

FL #21857

AL-FAROOQ CORPORATION
ENGINEERS & PRODUCT DEVELOPMENT
9360 SUNSET DRIVE, SUITE 220
MIAMI, FLORIDA 33173
TEL. (305) 262-6978 FAX. (305) 262-6978
COMP-ANL \ W15-28TMW

SERIES 605 ALUMINUM SINGLE HUNG WDW. (L.M.I.)
Assura Windows & Doors, LLC.
1543 N. Powerline Road
Pompano Beach, FL 33069
Tel. (954) 781-4430 www.assurawindows.com

revisions:	no.	date	description

date: 06-29-15
scale: 1/2" = 1"
dr. by: TARIQ
chk. by:

drawing no.
W15-28
sheet 2 of 7

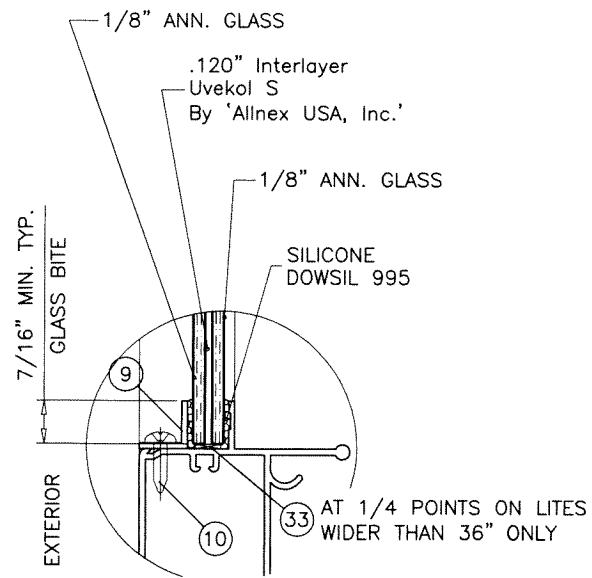

GLASS TYPE 'C'

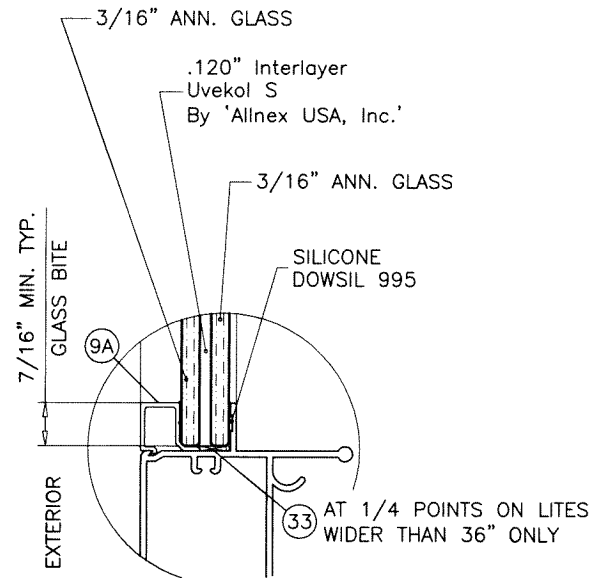

GLASS TYPE 'D'

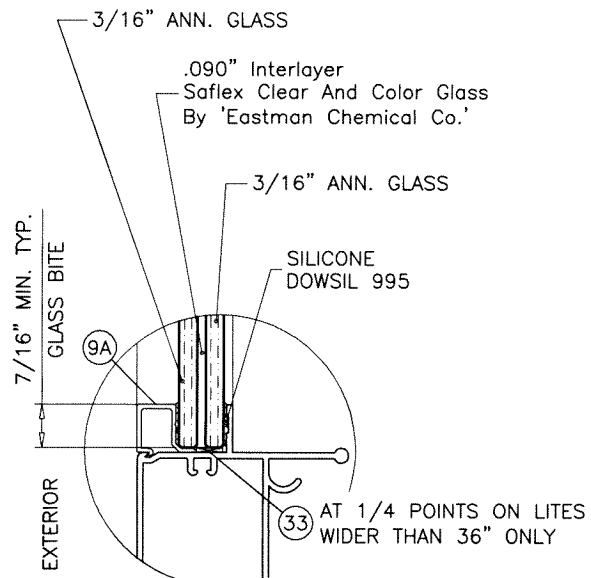

GLASS TYPE 'E'

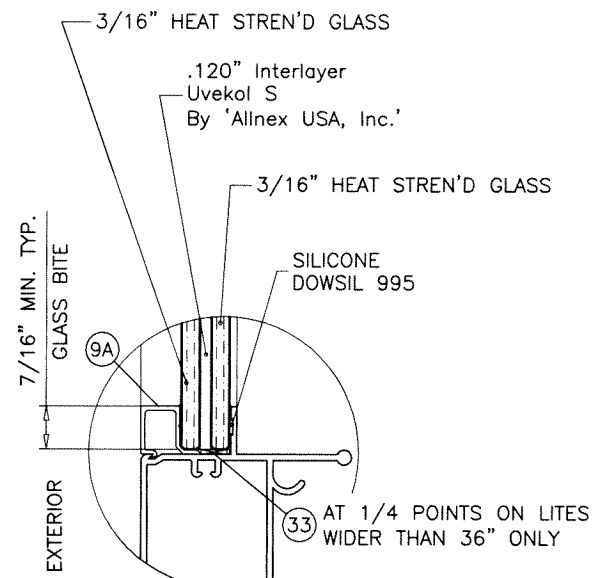

GLASS TYPE 'F'

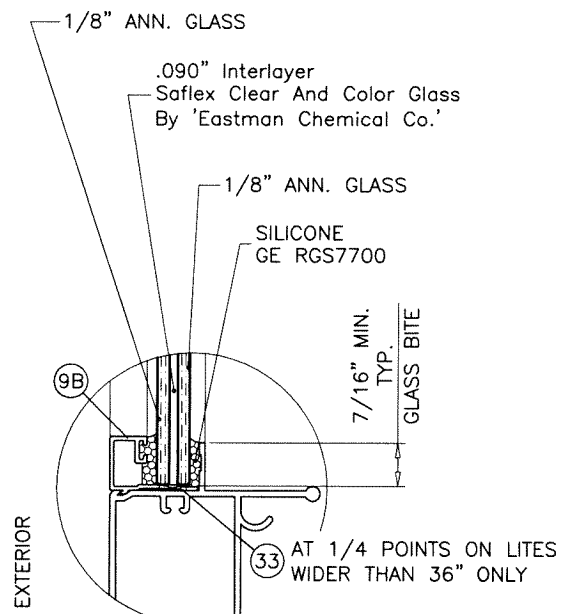

GLASS TYPE 'G'

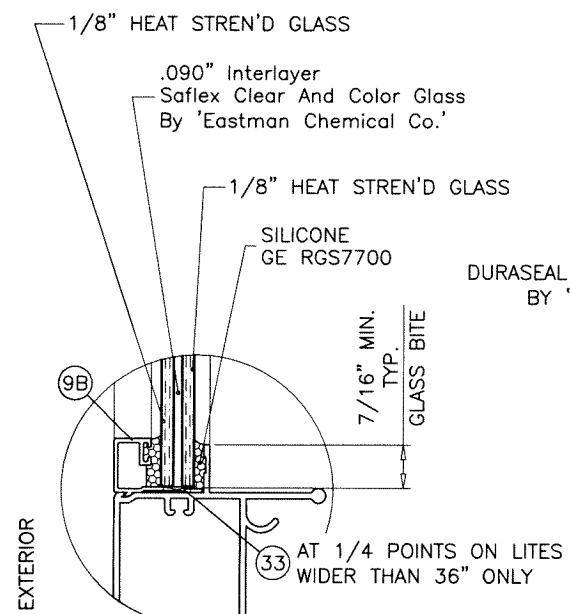

GLASS TYPE 'H'

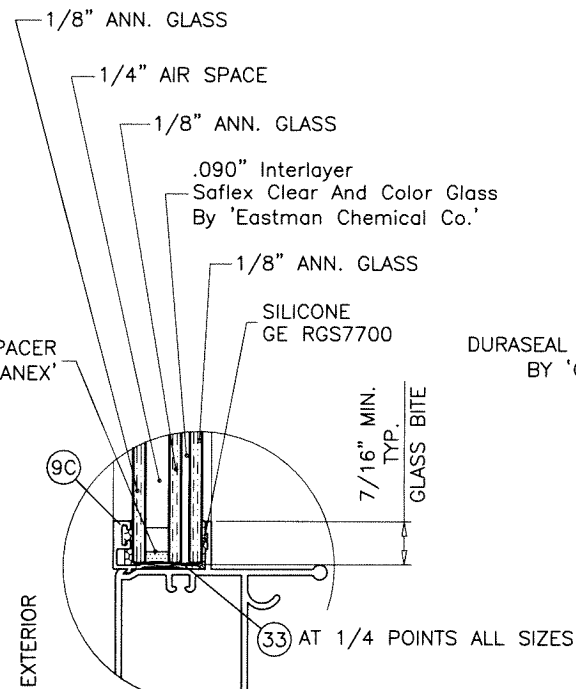

GLASS TYPE 'I'

THIS GLASS TYPE ONLY FOR
LARGE MISSILE IMPACT USE.
NOT QUALIFIED FOR SMALL
MISSILE IMPACT AREAS.

GLAZING OPTIONS

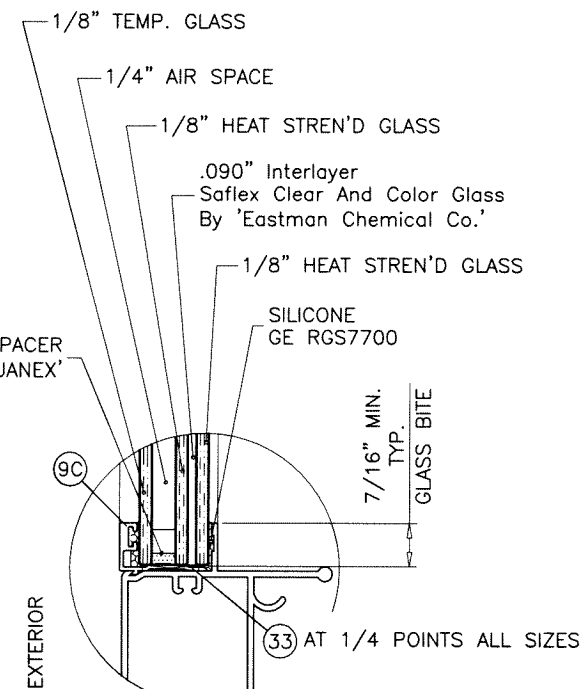

GLASS TYPE 'J' Sealed:7/20/2023

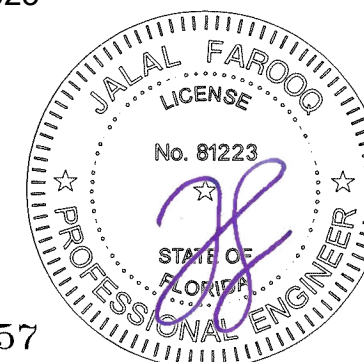

FL #21857

af c
AL-FAROOQ CORPORATION
 ENGINEERS & PRODUCT DEVELOPMENT
 9360 SUNSET DRIVE, SUITE 220
 MIAMI, FLORIDA 33173 (C.A.N. 3538)
 TEL. (305) 264-8100 FAX. (305) 262-6978
 COMP-ANL\W15-28TMW

SERIES 605 ALUMINUM SINGLE HUNG WDW. (L.M.I.)
Assura Windows & Doors, LLC.
 1543 N. Powerline Road
 Pompano Beach, FL. 33069
 Tel. (954) 781-4430 www.assurawindows.com

revisions:

no	date	by	description

date: 06-29-15	scale: 1/2" = 1"
dr. by: TARIQ	chk. by:

drawing no.	W15-28
sheet	3 of 7

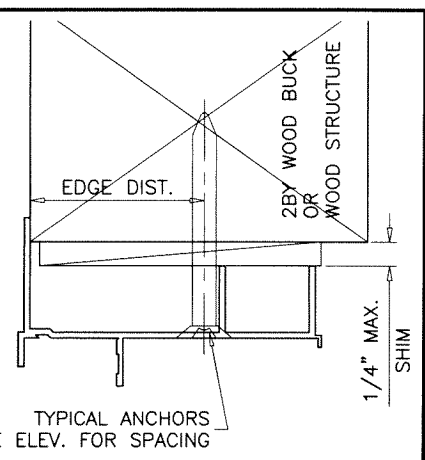
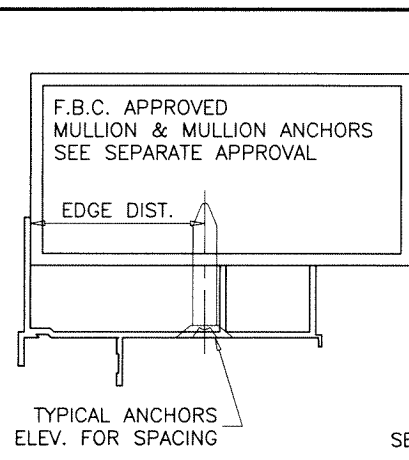
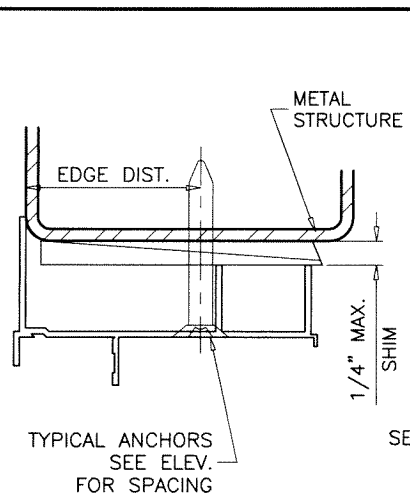
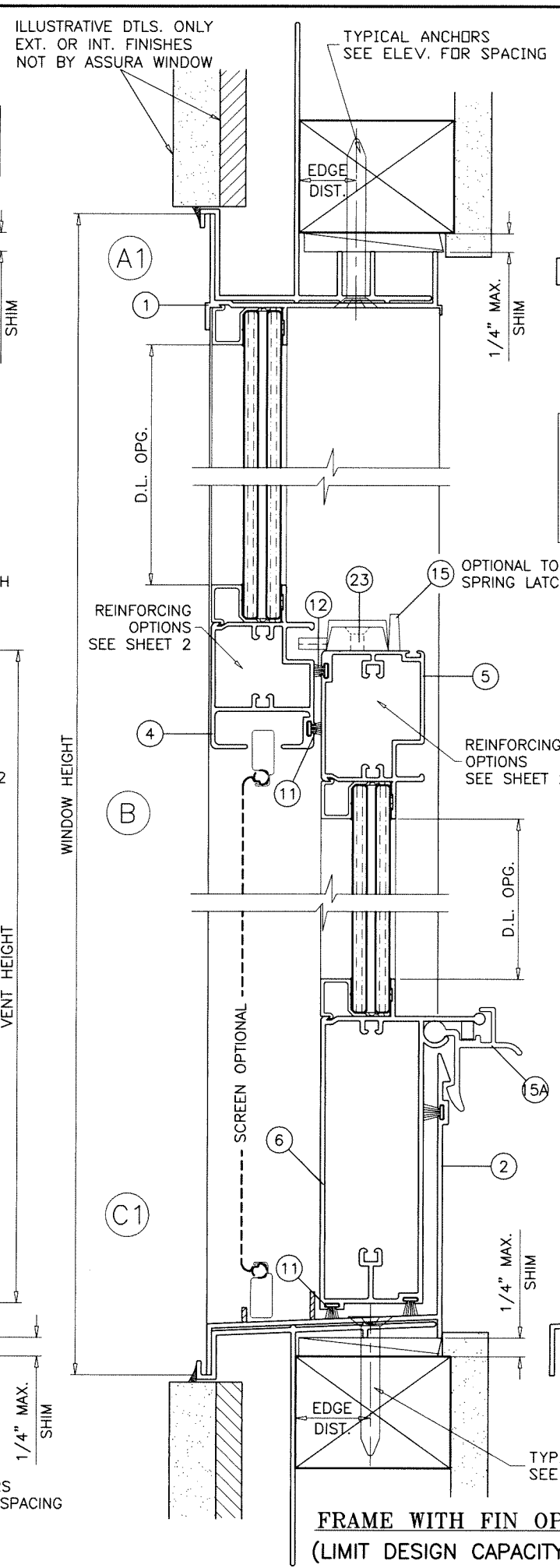
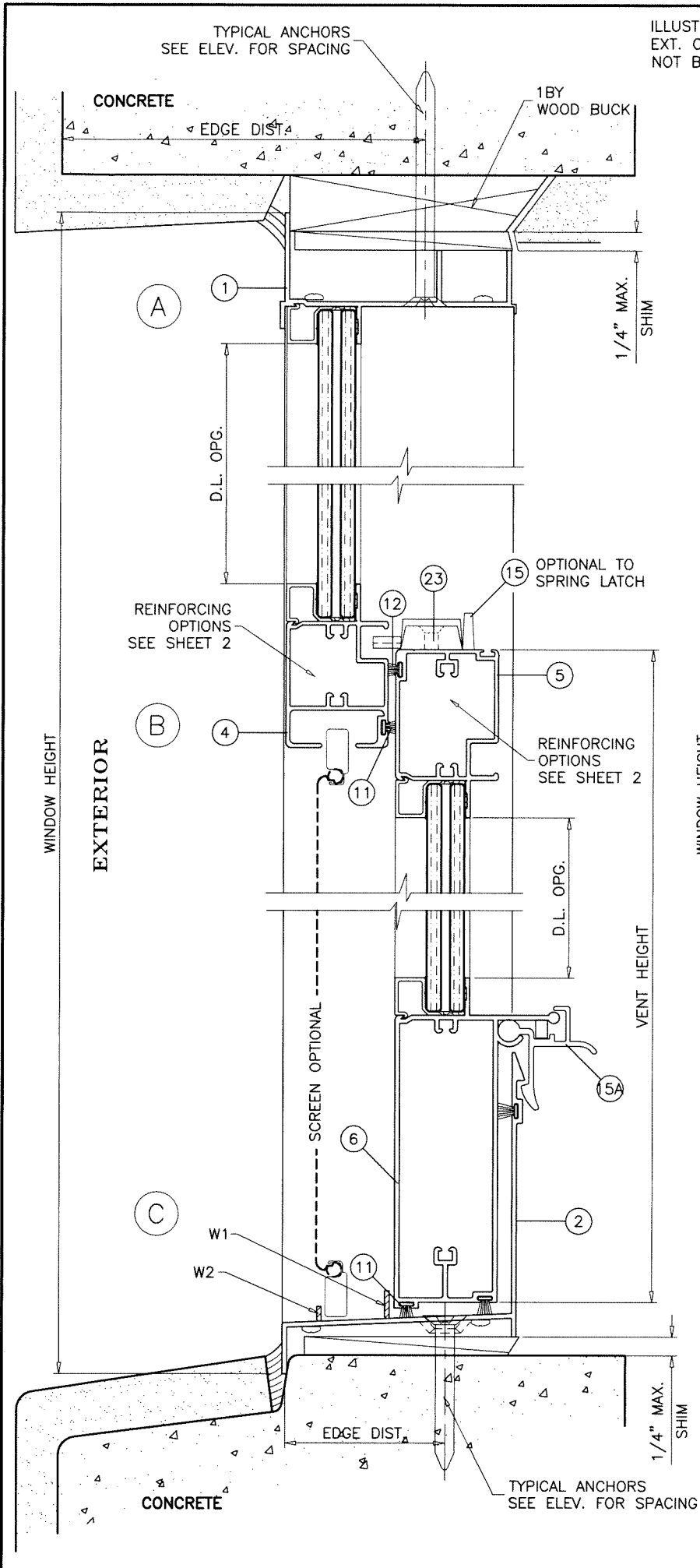

WOOD BUCKS AND METAL STRUCTURE NOT BY 'ASSURA WINDOWS' MUST SUSTAIN LOADS IMPOSED BY GLAZING SYSTEM AND TRANSFER THEM TO THE BUILDING STRUCTURE.

TYPICAL ANCHORS: SEE ELEV. FOR SPACING

1/4" DIA. ULTRACON+ BY 'DEWALT' (Fu=164 KSI, Fy=148 KSI) INTO 2BY WOOD BUCKS OR WOOD STRUCTURES 1-1/2" MIN. PENETRATION INTO WOOD (HEAD/SILL/JAMBS) THRU 1BY BUCKS INTO CONC. OR BLOCKS 1-1/4" MIN. EMBED INTO CONCRETE (HEAD/SILL/JAMBS) 1-1/4" MIN. EMBED INTO BLOCKS (JAMBS)

DIRECTLY INTO CONCRETE OR BLOCKS 1-1/4" MIN. EMBED INTO CONCRETE (HEAD/SILL/JAMBS) 1-1/4" MIN. EMBED INTO BLOCKS (JAMBS)

#14 SMS OR SELF DRILLING SCREWS (GRADE 2 CRS) INTO METAL STRUCTURES (HEAD/SILL/JAMBS) (3) THREADS MIN. PENETRATION BEYOND SUBSTRATE ALUMINUM: 1/8" THK. MIN. (6063-T5 MIN.) STEEL: 1/8" THK. MIN. (Fy = 36 KSI MIN.) (STEEL IN CONTACT WITH ALUMINUM TO BE PLATED OR PAINTED)

#12 SMS OR SELF DRILLING SCREWS (GRADE 2 CRS) INTO F.B.C. APPROVED MULLIONS (NO SHIM SPACE) (3) THREADS MIN. PENETRATION BEYOND SUBSTRATE ALUMINUM: 1/8" THK. MIN. (6063-T5 MIN.) STEEL: 1/8" THK. MIN. (Fy = 36 KSI MIN.) (STEEL IN CONTACT WITH ALUMINUM TO BE PLATED OR PAINTED)

TYPICAL EDGE DISTANCE

INTO CONCRETE AND MASONRY = 2" MIN.
INTO WOOD STRUCTURE = 1" MIN.
INTO METAL STRUCTURE = 3/4" MIN.

WOOD AT HEAD, SILL OR JAMBS SG = 0.55 MIN.
CONCRETE AT HEAD, SILL OR JAMBS f'c = 3000 PSI MIN.
C-90 HOLLOW/FILLED BLOCK AT JAMBS f'm = 2000 PSI MIN.

Sealed: 7/20/2023

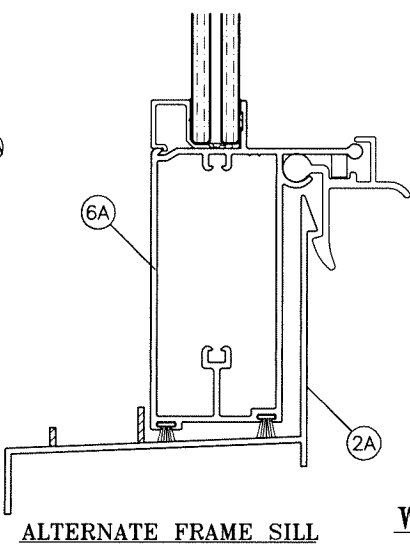

FRAME WITH FIN OPTION
(LIMIT DESIGN CAPACITY TO ±61.0 PSF MAX.)

WEEPHOLES:

W1 = 1/2" LONG NOTCH AT EACH END OF INTERIOR LEG

W2 = 7/8" LONG NOTCH AT EACH END OF EXTERIOR LEG

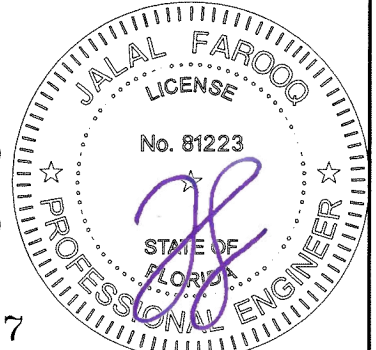

af c

AL-FAROOQ CORPORATION
ENGINEERS & PRODUCT DEVELOPMENT
9360 SUNSET DRIVE, SUITE 220
MIAMI, FLORIDA 33173
TEL. (305) 264-8100 FAX. (305) 262-6978
COMP-ANL W15-28TMW

SERIES 605 ALUMINUM SINGLE HUNG WDW. (L.M.I.)

Assura Windows & Doors, LLC.
1543 N. Powerline Road
Pompano Beach, FL 33069
Tel. (954) 781-4430 www.assurawindows.com

revisions:	no	date	by	description
date:	06-29-15	scale:	1/2" = 1"	
dr. by:	TARIQ	chk. by:		
drawing no.	W15-28			
sheet	4 of 7			

FL #21857

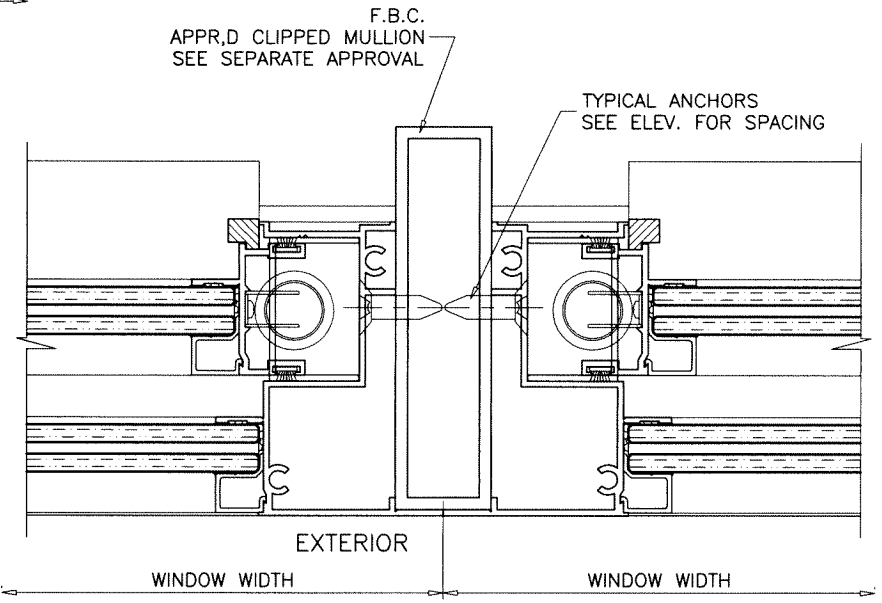
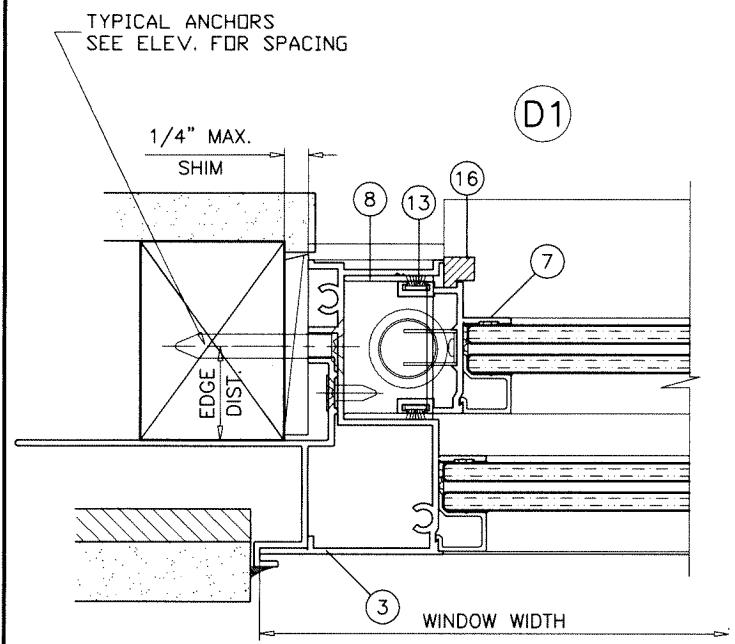
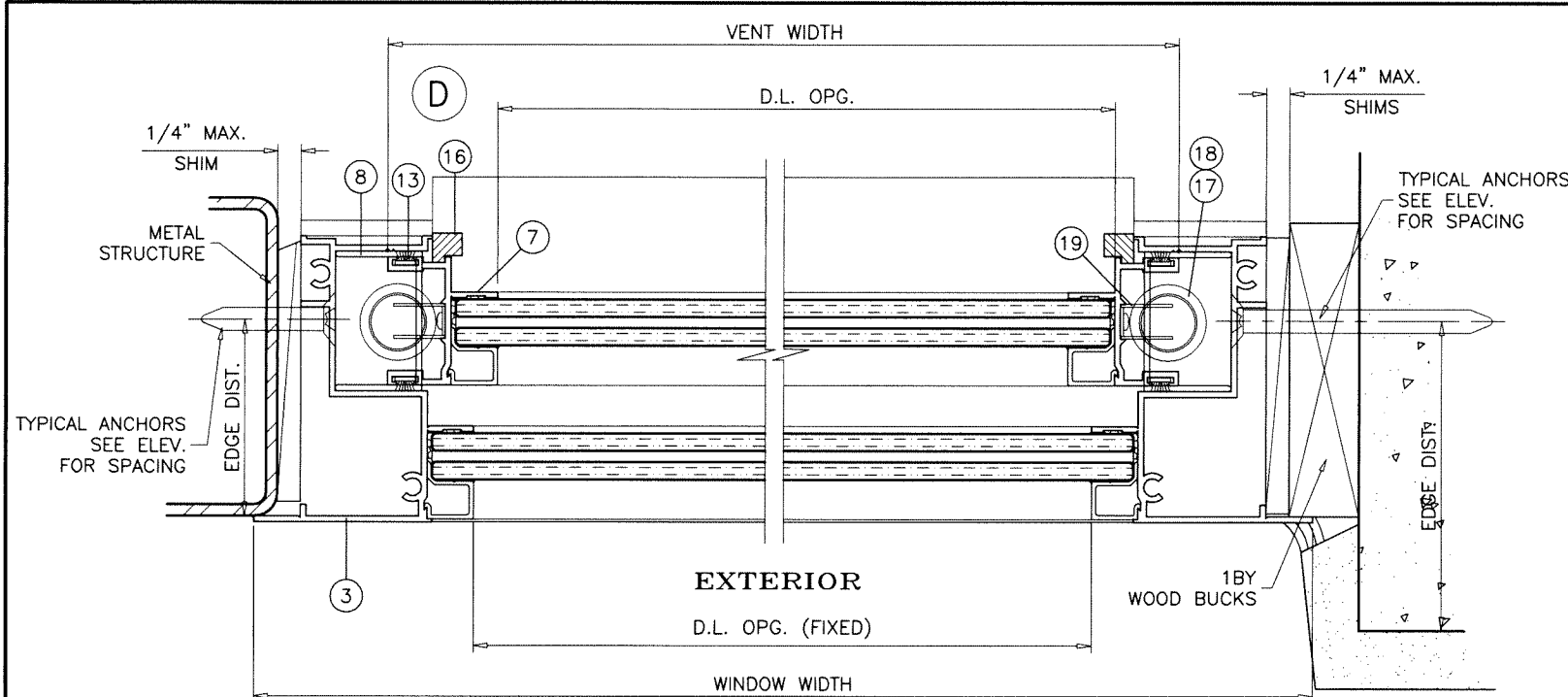

ITEM	PART #	QTY.	DESCRIPTION	MATERIAL	MANF./SUPPLIER/REMARKS
1	GW-36763	1	FRAME HEAD	6063-T6	-
2	GW-37731	1	FRAME SILL (4" HIGH)	6063-T6	-
2A	BA-3608	1	FRAME SILL (3" HIGH)	6063-T6	-
3	GW-31445	2	FRAME JAMB	6063-T6	-
4	GW-36706	1	MEETING RAIL	6063-T6	-
5	GW-36685	1	VENT TOP RAIL	6063-T6	-
6	GW-37730	1	VENT BOTTOM RAIL (4" SILL)	6063-T6	-
6A	GW-37559	1	VENT BOTTOM RAIL (3" SILL)	6063-T6	-
7	GW-31134	2	VENT JAMB STILE	6063-T6	-
8	GW-31470	2	VENT STOP	6063-T5	-
9	19-56	4/VENT	GLAZING BEAD ANGLE	6063-T5	-
9A	TM-123	4/VENT	GLAZING BEAD	6063-T5	-
9B	TM-170	4/VENT	GLAZING BEAD	6063-T6	-
9C	TM-181	4/VENT	GLAZING BEAD (INSUL. LAM. GLASS)	6063-T6	-
10	#8 X 1/2"	12/VENT	GLAZING ANGLE SCREWS	STEEL	PH SMS
11	4037	(1) STRIP	FIN SEAL WEATHERSTRIP	-	MTG.RAIL/FRAME SILL
12	2240	(1) STRIP	FIN SEAL WEATHERSTRIP	-	VENT TOP
13	3722	(2) STRIP	FIN SEAL WEATHERSTRIP	-	VENT JAMB STILES
14	-	2	1 1/2"x7/8"x3/4" FINSEAL PAD	-	FRAME SILL CORNERS
15	-	2/VENT	LATCH LOCK AT 5" FROM ENDS	CAST	VENT TOP
15A	TM-118A	2/VENT	SPRING LOADED EGRESS LOCK	6063-T6	VENT BOTTOM RAIL
16	-	4/VENT	VENT GUIDE	NYLON	VENT INT. CORNERS
17	-	2/VENT	CALDWELL SPIRAL BALANCES	-	AT FRAME JAMBS
18	WVR-9302	2/VENT	BALANCE COVER	VINYL	FRAME HEAD/JAMBS
19	N69	2/VENT	CALDWELL BALANCE CLIP	-	VENT BOTT. CORNERS
20	-	2	#12 x 3/4" P.H. SMS	STEEL	(1) AT EACH BALANCE
21	-	8	#12 x 1" P.H. SMS	STEEL	FRAME CORNERS
22	-	8	#10 x 1" P.H. SMS	STEEL	VENT CORNERS
23	-	4	#8 x 3/4" F.H. SMS.	STEEL	(2) AT EACH LATCH
24	-	4	#6 x 3/8" F.H. SMS.	STEEL	AT EA. PLASTIC GUIDE
25	-	1	1x1 3/16x3/4x1/8" CHANNEL	STEEL	AT VENT TOP
26	-	2	1x1/4 THK.x4" LONG BAR	ALUM.	(1) AT EA. MTG. RAIL END
27	-	1	1/2x1x1/2x1/8" CHANNEL	STEEL	AT MEETING RAIL
28	TM-161	2	FIN TRIM FOR JAMBS	6063-T6	-
29	TM-163	1	FIN TRIM FOR HEAD	6063-T6	-
30	TM-164	1	FIN TRIM FOR SILL	6063-T6	-
31	TM-179	1	MTG. RAIL REINFORCING CHANNEL	6063-T5	AT MEETING RAIL
32	TM-178	1	TOP RAIL REINFORCING CHANNEL	6063-T5	AT VENT TOP
33	-	AS REQD.	SETTING BLOCKS	EPDM	DUROMETER 80±5 SHORE A

SEALANTS:
ALL JOINTS AND FRAME CONNECTIONS SEALED WITH SILICONE OR ACRYLIC SEALANT.

Sealed:7/20/2023

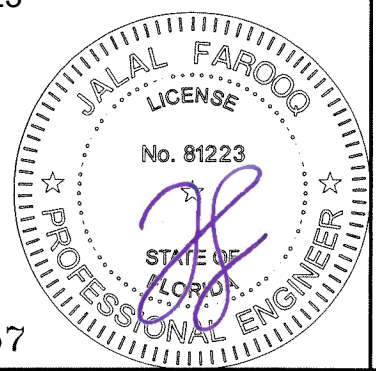

FL #21857

af c
AL-FAROOQ CORPORATION
ENGINEERS & PRODUCT DEVELOPMENT
9360 SUNSET DRIVE, SUITE 220
MIAMI, FLORIDA 33173 (C.A.N. 3538)
TEL. (305) 264-8100 FAX. (305) 262-6978
COMP-ANL\W15-28TMW

SERIES 605 ALUMINUM SINGLE HUNG WDW. (L.M.I.)
Assura Windows & Doors, LLC.
1543 N. Powerline Road
Pompano Beach, FL. 33069
Tel. (954) 781-4430 www.assurawindows.com

revisions:	no	date	by	description
date:	06-29-15	scale:	1/2" = 1"	
dr. by:	TARIQ	chk. by:		
drawing no.	W15-28			
sheet	5 of 7			

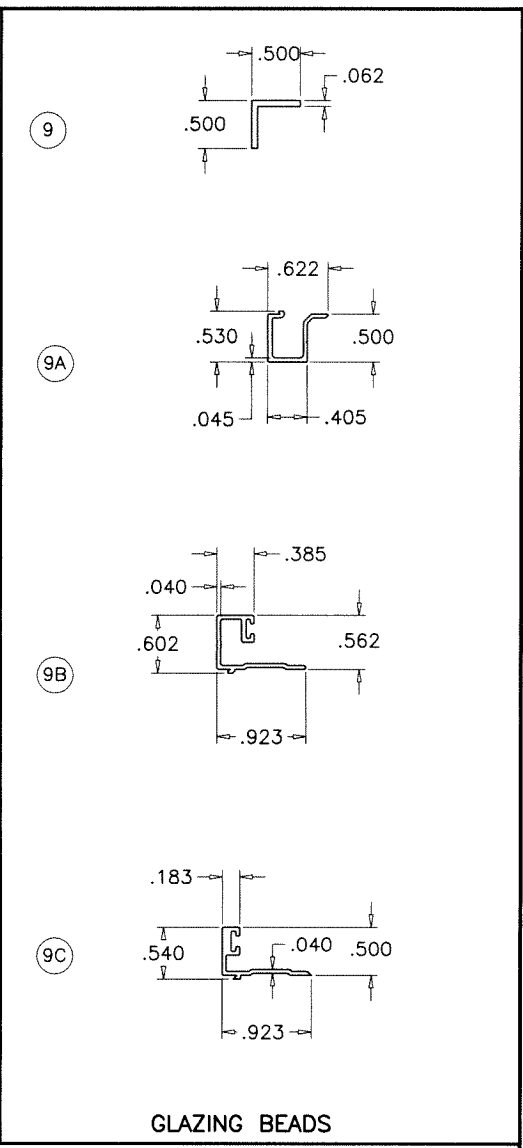
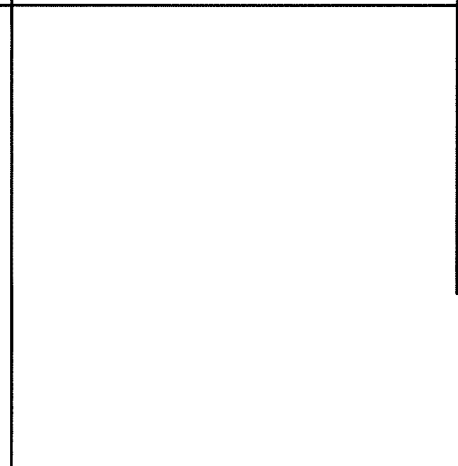
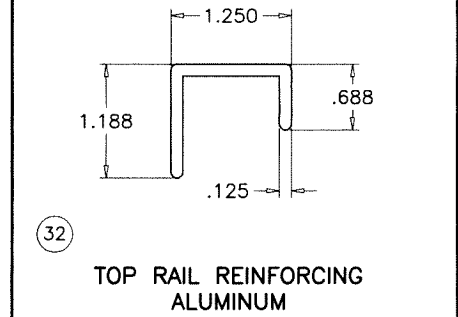
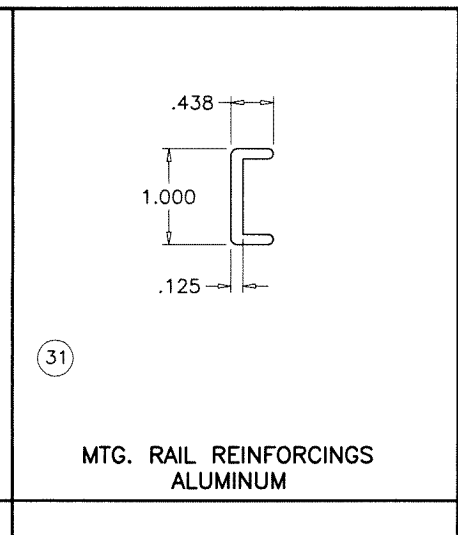
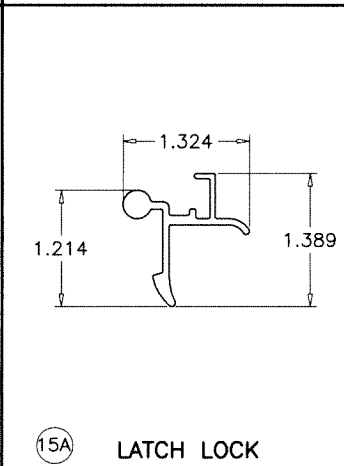
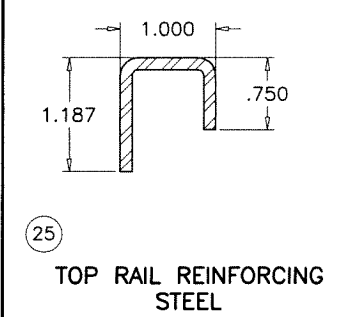
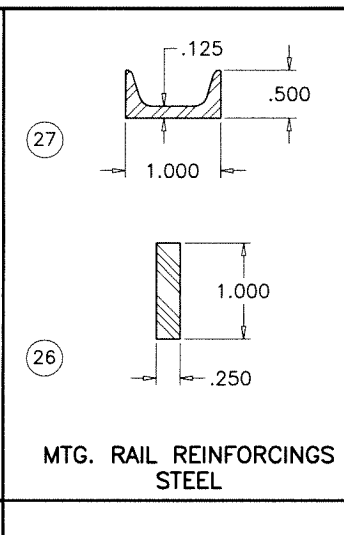
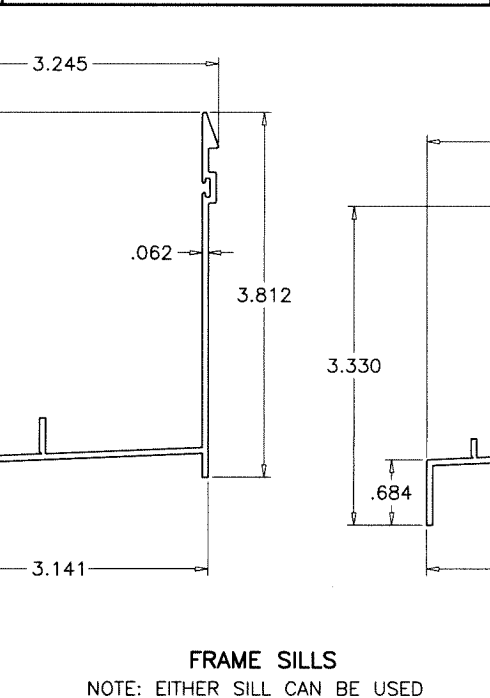
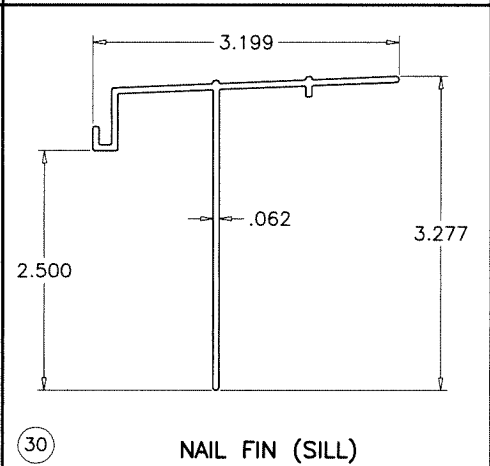
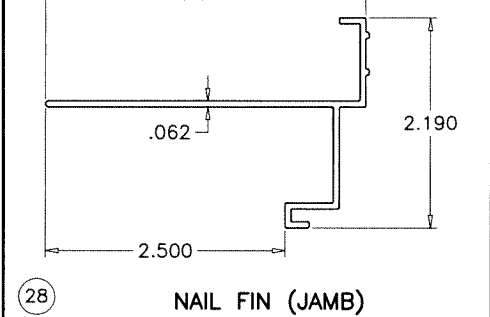
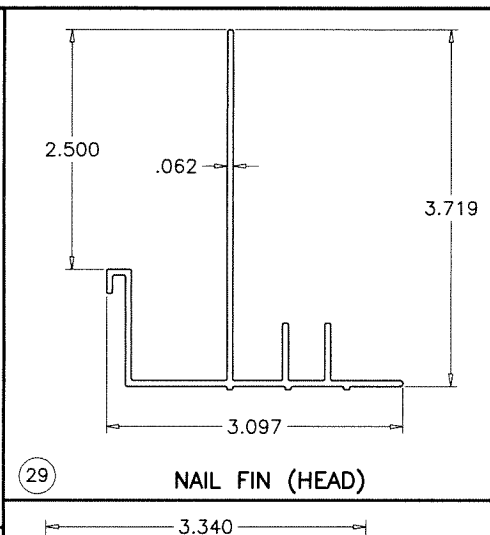
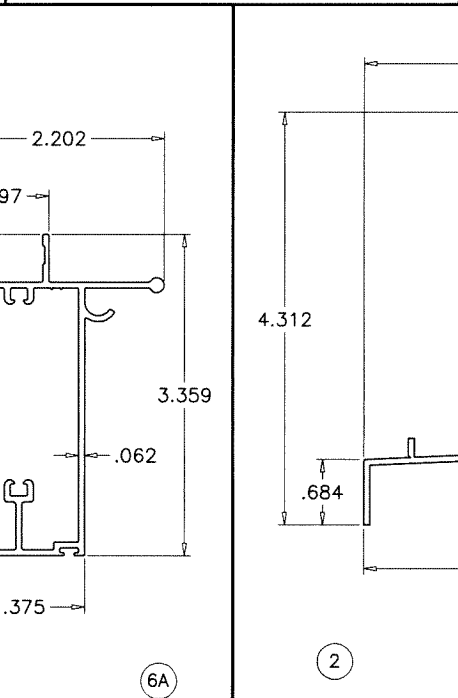
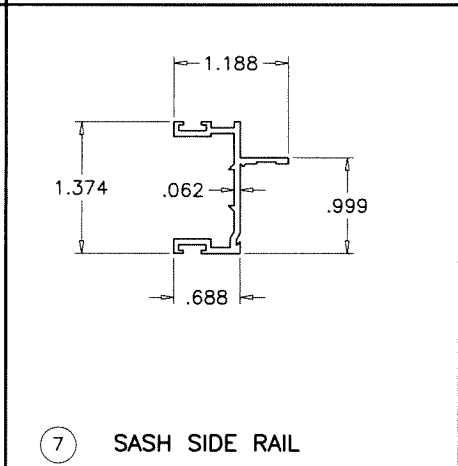
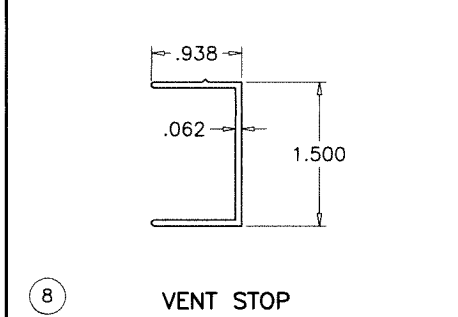
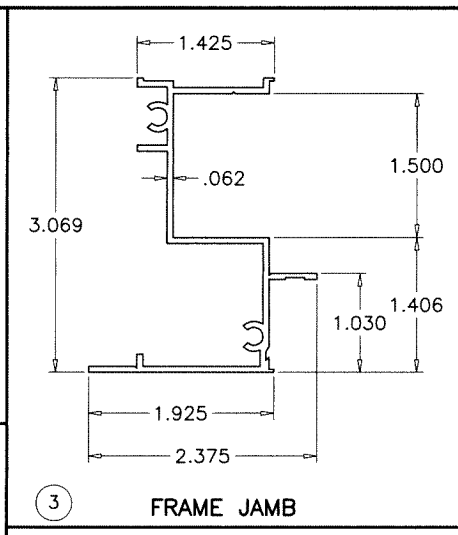
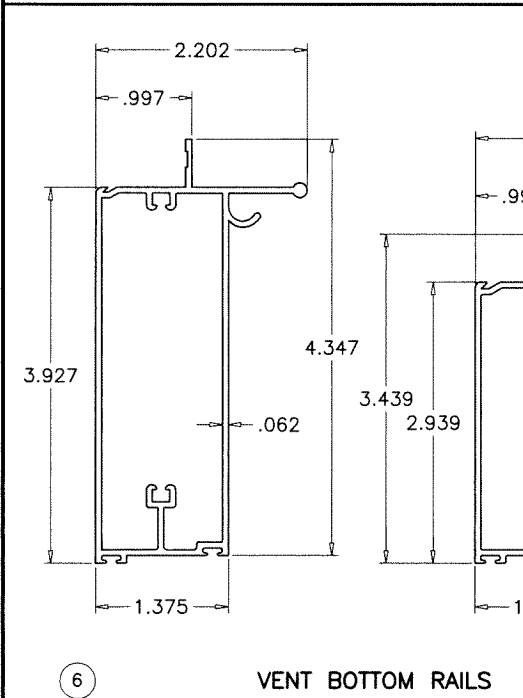
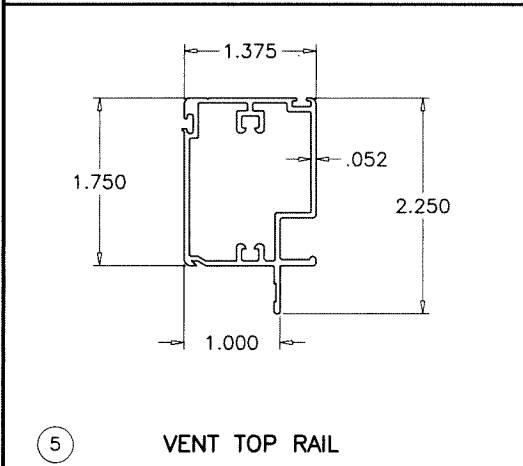
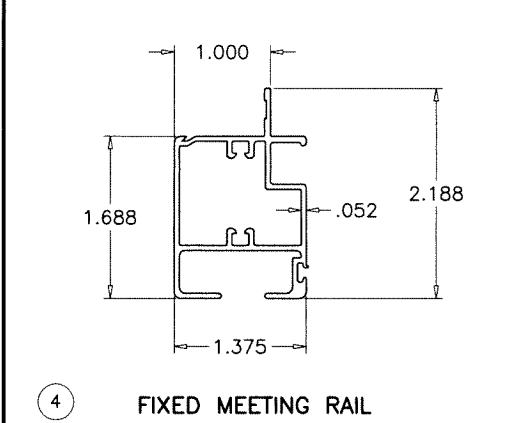
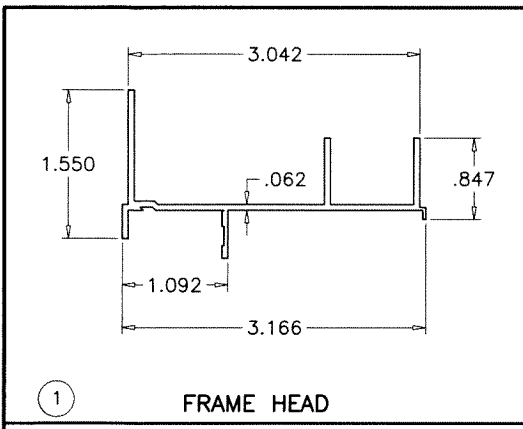

NOTE: EITHER SILL CAN BE USED

Sealed: 7/20/2023

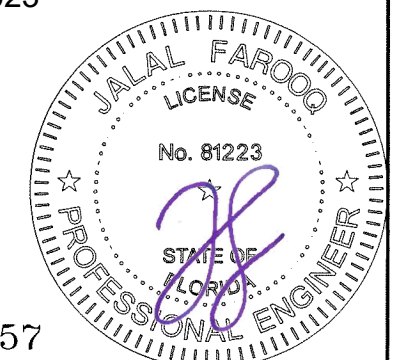

FL #21857

af c
AL-FAROOQ CORPORATION
 ENGINEERS & PRODUCT DEVELOPMENT
 9360 SUNSET DRIVE, SUITE 220
 MIAMI, FLORIDA 33173 (C.A.N. 3538)
 TEL. (305) 264-8100 FAX. (305) 262-6978
 COMP - ANL \ W15 - 28TMW

SERIES 605 ALUMINUM SINGLE HUNG WDW. (L.M.I.)
Assura Windows & Doors, LLC.
 1543 N. Powerline Road
 Pompano Beach, FL 33069
 Tel. (954) 781-4430 www.assurawindows.com

no	date	by	description

date: 06-29-15
 scale: 1/2" = 1"
 dr. by: TARIQ
 chk. by:

drawing no.
W15-28
 sheet 6 of 7

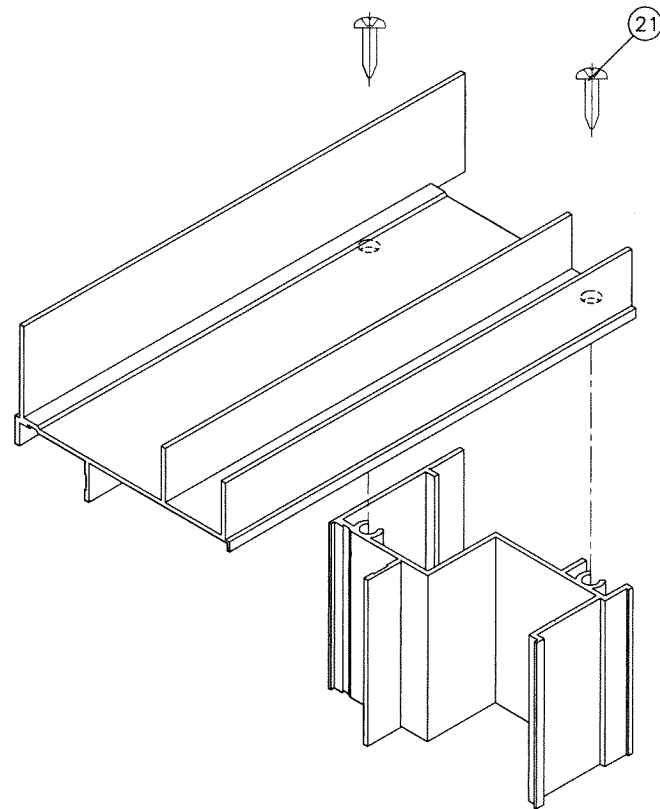

FRAME TOP CORNER

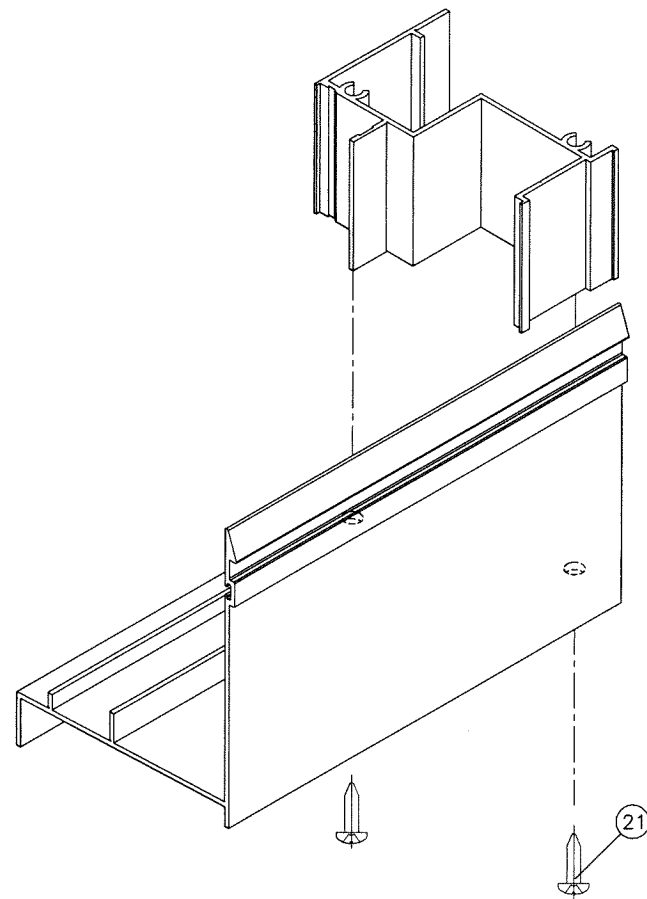

FRAME BOTTOM CORNER

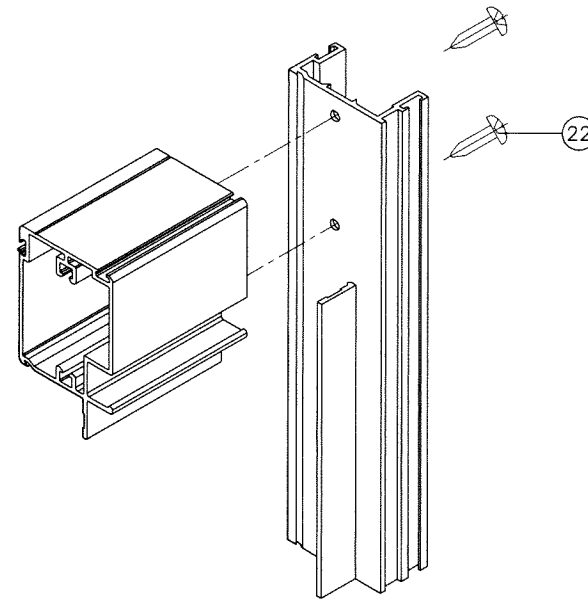

VENT TOP CORNER

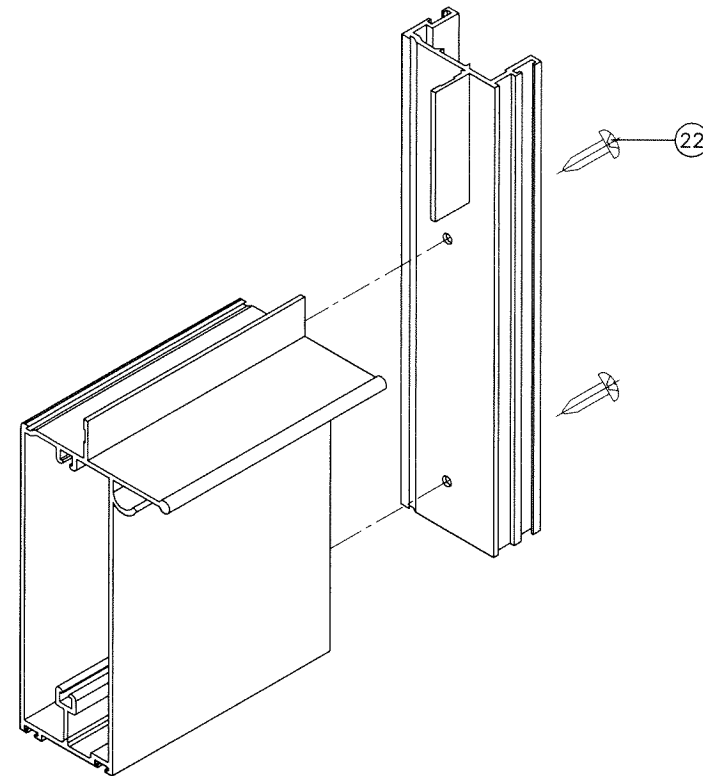

VENT BOTTOM CORNER

Sealed:7/20/2023

FL #21857

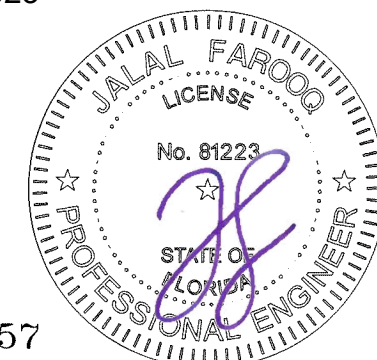

afc
AL-FAROOQ CORPORATION
 ENGINEERS & PRODUCT DEVELOPMENT
 9360 SUNSET DRIVE, SUITE 220
 MIAMI, FLORIDA 33173 (C.A.N. 3538)
 TEL. (305) 264-8100 FAX. (305) 262-6978
 COMP--ANL \ W15-28TMW

SERIES 605 ALUMINUM SINGLE HUNG WDW. (L.M.I.)
Assura Windows & Doors, LLC.
 1543 N. Powerline Road
 Pompano Beach, FL. 33069
 Tel. (954) 781-4430 www.assurawindows.com

revisions:	no	date	by	description

date: 06-29-15
 scale: 1/2" = 1"
 dr. by: TARIQ
 chk. by:

drawing no.
W15-28
 sheet 7 of 7